









EVALUATION AND REPAIR OF  
CONCRETE SLABS

By

ROBERT W. SIEGFRIED

A REPORT PRESENTED TO THE GRADUATE COMMITTEE  
OF THE DEPARTMENT OF CIVIL ENGINEERING IN  
PARTIAL FULFILLMENT OF THE REQUIREMENTS  
FOR THE DEGREE OF MASTER OF ENGINEERING

UNIVERSITY OF FLORIDA

SUMMER 1992

T260674



EVALUATION AND REPAIR OF  
CONCRETE SLABS

By

ROBERT W. SIEGFRIED

A REPORT PRESENTED TO THE GRADUATE COMMITTEE  
OF THE DEPARTMENT OF CIVIL ENGINEERING IN  
PARTIAL FULFILLMENT OF THE REQUIREMENTS  
FOR THE DEGREE OF MASTER OF ENGINEERING

UNIVERSITY OF FLORIDA

SUMMER 1992

110515  
340345  
a.1



To Sally, my wife and my friend, your sacrifice and commitment to our family made it possible to meet this goal in my life. Your company, support, and love made it a lot easier. And to my children, Amie and William, your love and your smiles make it all worthwhile.



## ACKNOWLEDGEMENTS

I would like to express my appreciation to Dr. Ronald Cook for his advice and suggestions, and for providing outstanding review during the writing of this report. Special thanks are extended to Dr. Zohar Herbsman and Dr. Byron Ruth for their participation on my supervisory committee.



## TABLE OF CONTENTS

DEDICATION . . . . .	i
ACKNOWLEDGEMENTS . . . . .	ii
LIST OF TABLES . . . . .	v
LIST OF FIGURES . . . . .	vi
CHAPTER I INTRODUCTION . . . . .	1
1.1 General . . . . .	1
1.2 Background . . . . .	1
1.3 Objectives . . . . .	3
1.4 Scope . . . . .	3
1.5 Report Overview . . . . .	4
CHAPTER II RECOGNIZING CONCRETE PROBLEMS . . . . .	6
2.1 Overview . . . . .	6
2.2 General Problem Causes . . . . .	7
2.2.1 Defects . . . . .	7
2.2.2 Damage . . . . .	8
2.2.3 Deterioration . . . . .	8
2.3 Problem Types . . . . .	9
2.3.1 Cracking . . . . .	10
2.3.1.1 Cracking . . . . .	11
2.3.1.2 Early Cracking . . . . .	14
2.3.1.3 Post-hardening Cracking . . . . .	19
2.3.2 Surface defects . . . . .	21
2.3.2.1 Scaling . . . . .	21
2.3.2.2 Dusting . . . . .	22
2.3.2.3 Blisters . . . . .	23
2.3.2.4 Spalling . . . . .	25
2.3.2.5 Popouts . . . . .	25
2.3.2.6 Honeycombing . . . . .	27



2.3.3	Joint deficiencies . . . . .	28
CHAPTER III	GENERAL REPAIR PRINCIPLES . . . . .	31
3.1	Overview . . . . .	31
3.2	Evaluating Concrete Problems . . . . .	31
3.3	Choosing a Repair Method . . . . .	33
3.4	Choosing a Repair Material . . . . .	35
3.4.1	Material Types . . . . .	36
3.4.2	Material Properties . . . . .	37
3.5	Preparations for Repair . . . . .	39
CHAPTER IV	MATERIALS AND METHODS OF REPAIR . . . . .	41
4.1	Overview . . . . .	41
4.2	Materials . . . . .	41
4.2.1	Cementitious Materials . . . . .	42
4.2.2	Polymers . . . . .	43
4.2.2.1	Resins/Polymers/Adhesives . . . . .	44
4.2.2.2	Polymer Concrete . . . . .	47
4.3	Methods of Repair . . . . .	50
4.3.1	Patching and Small Scale Repairs . . . . .	51
4.3.2	Concrete Replacement . . . . .	53
4.3.3	Repairs to Cracks . . . . .	54
4.3.3.2	Epoxy Injection Repairs . . . . .	56
4.3.4	Repairs to Joints . . . . .	59
CHAPTER V	CONCLUSION AND RECOMMENDATIONS . . . . .	61
5.1	Conclusion . . . . .	61
5.2	Recommendations . . . . .	63
APPENDIX A	- Guide for Making a Condition Survey of Concrete Pavements (ACI 201.3R-86) . . . . .	66
APPENDIX B	- Identification and Control of Consolidation-related Defects (ACI 309.2R-82) . . . . .	89
APPENDIX C	- Causes, Evaluation, and Repair of Cracks in Concrete Structures (ACI 224.1R-89) . . . . .	101





LIST OF TABLES

<b>Table 4.1</b>	Grades and Classes of Type I Epoxies . . . .	46
<b>Table 4.2</b>	Extra Material Cost/Sq. Foot of Overlay . .	50
<b>Table 4.3</b>	Tolerable Crack Widths . . . . .	55



## LIST OF FIGURES

<b>Figure 2.1</b>	Crazing Concrete Surface . . . . .	12
<b>Figure 2.2</b>	Map Cracking . . . . .	12
<b>Figure 2.3</b>	Typical plastic shrinkage cracking . . . . .	16
<b>Figure 2.4</b>	Severe Plastic shrinkage cracks in a floor slab. . . . .	16
<b>Figure 2.5</b>	Shifting Form Crack . . . . .	17
<b>Figure 2.6</b>	Obstructed settlement crack. . . . .	18
<b>Figure 2.7</b>	Restraint causes drying shrinkage cracks .	19
<b>Figure 2.8</b>	Typical drying shrinkage cracks . . . . .	20
<b>Figure 2.9</b>	Scaled concrete . . . . .	22
<b>Figure 2.10</b>	Concrete blisters . . . . .	23
<b>Figure 2.11</b>	Concrete blister formation . . . . .	24
<b>Figure 2.12</b>	Typical popouts . . . . .	26
<b>Figure 2.13</b>	Surface Honeycombing . . . . .	27
<b>Figure 2.14</b>	Honeycombing within concrete . . . . .	28
<b>Figure 2.15</b>	Causes of joint edge spalling . . . . .	30



## CHAPTER I INTRODUCTION

### 1.1 General

Concrete is normally thought of as a solid, reliable, and mostly maintenance-free construction material. Indeed, if properly designed, produced and placed, concrete will provide long service with little maintenance. But, all structures inevitably age and deteriorate, regardless of how well they were designed and built. In today's economic climate, the demand for new construction has diminished significantly. Owners are looking for ways to cut costs, and often end up renovating more and building less. In this environment, construction professionals must be thoroughly knowledgeable of how to properly renovate and repair concrete structures, and how to ensure the new facilities they build will remain durable, and not deteriorate prematurely .

### 1.2 Background

Most concrete structures are rarely beyond repair, and there is nearly an unlimited selection of repair products and processes available to restore them. Epoxies, acrylics, polyesters, cementitious grouts, mortars, and shotcrete mixes can all be used for concrete repair. These products are sold



in a wide variety of packages and price ranges, and each product has its own specific features, benefits, and uses.

Accordingly, repair contractors are faced with the difficult decision of which product to use for the specific problem at hand. Cost cannot, and should not, be the only consideration. Factors concerning the actual concrete to be repaired, such as its location in the structure, the environment to which it is exposed, and the length of time the repair must last, must be considered. In addition, the repair product itself must be taken into account. "Critical factors such as bonding capability, shrinkage, expansion, strength, thermal compatibility, ease of application, waterproofing, freeze/thaw and abrasion resistance" [1:151] of the repair material must be considered.

Selection of the proper repair method and material further depends on the type of problem to be corrected, and its cause. Concrete problems are classified, according to their root cause as: deterioration, damage, and defects. These major classifications can be further broken down for specific causes. For example, "deterioration of concrete in service may be the result of a variety of physical and chemical processes, such as attack by acids, sulfates, or alkalis, alkali-aggregate reactions, freeze-thaw cycles, etc." [2:186]

In short, the contractor contemplating a concrete repair must consider many factors to ensure a durable and strong





repair. The specific problem, its underlying cause, the importance of the repair, and the benefits and costs of specific repair methods/materials, must all be determined and addressed.

### 1.3 Objectives

The purpose of this report is to review the different types and causes of concrete failure, and to outline those factors which a contractor must consider when selecting a repair strategy. The report will further discuss how to recognize, evaluate, and repair common concrete problems which occur during construction, or as a direct result of improper construction practices. The report will also outline how these common problems can be avoided or prevented in the first place.

### 1.4 Scope

When repairing a concrete structure, the various elements of that structure each require special consideration. To present information on all of the different types of problems, for each of these structural elements is beyond the scope of one paper. This report will concentrate on those problems typically encountered with concrete slabs. The report will summarize the current information on recognizing, repairing, and preventing concrete damage, defects, and deterioration to slabs. Emphasis will be accorded to those problems which



occur during construction, or are caused by the construction itself. Since deterioration normally occurs over a long period of time, and; therefore, is not an immediate concern of the construction contractor, its evaluation and repair will not be discussed in detail.

### 1.5 Report Overview

Chapter two describes the differences between the three classes of concrete problems; damage, defects, and deterioration. The chapter describes in detail the typical problems encountered during, and shortly after construction of concrete slabs, and provides parameters which a contractor can use to identify these problems, and their causes.

Simple recognition of a problem is not sufficient to ensure a proper, long-lasting repair. The cause of the problem also plays a significant role in determining the proper repair method. Chapter three introduces the condition survey as a means of evaluating the causes of the typical problems discussed in chapter two.

The heart of the report is in chapter four. This chapter outlines the repair materials and methods available today, and evaluates which are best for repairing construction related problems. Chapter four will also provide general recommended procedures for each of the repair techniques.

Perhaps the requirement for concrete repair may never be eliminated; but, through sound construction practices



potential problems can be greatly reduced. Chapter five provides recommendations and conclusions concerning concrete repairs and ways for contractors to avoid or prevent the most common problems encountered with slabs. Incorporating these comments into daily construction practice will help to reduce common slab construction problems, and provide the wherewithal to correct those which do occur.



## CHAPTER II RECOGNIZING CONCRETE PROBLEMS

### 2.1 Overview

Problems with concrete occur in many forms, and as a result of a wide variety of causes. Some of these problems occur long after the contractor has completed construction and left the jobsite. Still others occur while the structure is being built, or soon after its completion. Several of these problems are a direct result of the construction practices used during the construction. "Many of the problems evident in hardened concrete are created in the forming, placing, and finishing of the concrete in the plastic stage. Some flaws are noticeable during, or shortly after, the initial set; others appear within a few days after placement." [3:69]

Early identification of concrete flaws is the first step to successful repair and prevention of further deterioration. To properly identify and repair a particular problem, a contractor must have knowledge of the cause and inherent characteristics of that problem. This chapter will provide a synopsis of the general causes of problems in concrete slabs, outline the common problem types encountered in slabs and their specific cause, and provide details concerning the appearance of these problems so they may be easily identified.





## 2.2 General Problem Causes

Over its lifetime, a concrete structure may exhibit myriad problems. These problems can generally be categorized according to their cause as: defects, damage, or deterioration. There are no strict guidelines for assigning a specific problem to one of the categories, as some concrete problems may be caused by any one of the three. Spalls, for instance, may be a result of corrosion-induced deterioration, impact damage, or a material defect. Concrete problems in any of the three categories may be caused by construction practice, but normally only defects and damage are readily apparent during, or soon after, construction.

### 2.2.1 Defects

A defect is an imperfection or fault which may limit or prohibit a structure's capability to perform its intended function. A defect may be as simple as a stain on the surface, or may be a much more serious structural flaw. Defects normally manifest themselves early in a structure's life. They are most commonly attributed to: wrong assumptions or errors in the design, improper material placement or construction practices, and deficient materials. Cracking, dusting, scaling, popouts, and honeycombing are common examples of concrete defects.



### 2.2.2 Damage

All structures are subject to damage that may preclude, or inhibit them from performing their intended function. Concrete structures, in particular, are exposed to weathering, chemical reactions within the concrete itself, and chemical or mechanical attack. Good, durable concrete is resistant to most routine exposures. For concrete which may be exposed to more severe conditions, additional protection can be provided. However, no protection is absolute, and damage does occur.

Although some damage occurs over the long-term, the constructor is more concerned with those damages which occur abruptly, or as the result of a specific event. Specific examples of these types of damage causing events include fires, earthquakes, impacts, abrasion, and overloads. The extent of damage from these causes will of course depend on the severity of the cause, and the strength of the affected member. Damage can range from small cracks to total failure. "Based on the capacity of the member and the nature and severity of the damage, its impact or significance will be more or less debilitating." [11:4] Regardless of the extent of damage, the concrete should be repaired immediately to prevent further damage or deterioration.

### 2.2.3 Deterioration

Deterioration is defined as "any adverse change of normal mechanical, physical and chemical properties either on the



surface or in the whole body of concrete generally through separation of its components." [4:4] There are many forms of deterioration that affect a concrete's ability to perform its intended function including: disintegration, deformation, corrosion, efflorescence, exudation, and incrustation. Some of the more common results of deterioration are spalling, scaling, popouts, and aggregate D-cracking. [11:4] While these end-results might be similar to those produced by damage and defects, the process is quite different.

Unlike damage and defects, deterioration tends to occur over a long period of time. Once the cause and effect of damage or defects are determined, an appropriate repair can be made. Deterioration, however, can create ongoing problems and can be harder to repair. "Deterioration also is harder to evaluate and correct because it often evolves in stages, over years of service." [11:5]

### 2.3 Problem Types

Aside from those contractors who specialize in the repair and rehabilitation of concrete structures, most contractors are only concerned with those concrete defects and damages that occur during, or shortly after, concrete placement. To repair these problems, the contractor must first know what is wrong before he can properly fix it. He must be able to identify the type of problem and its probable cause before he can attempt any repair. Concrete problems which concern these



contractors can be grouped into the three major categories of cracking, surface defects, and joint deficiencies. This section will outline the problem types which fall under these categories, and provide details concerning their appearance and cause.

### 2.3.1 Cracking

Simply defined, a crack is "an incomplete separation into one or more parts with or without space between." [4:4] On any concrete structure the chance that cracks will occur is high. Cracking is the most common concrete defect, but also the most difficult to evaluate. This is true because "the same cause may manifest itself in different crack patterns, while similar patterns may be due to different causes." [5:11] Cracks have many causes, and their effect can vary from an insignificant surface defect to significant structural distress. [6:1]

In general, cracking occurs when the concrete is restrained from the movement brought about by volume change. "Concrete, like other construction materials, contracts and expands with changes in moisture content and temperature ..." [5:191] Failure to provide for these movements can result in cracking of the concrete. Cracking may also result from overloading, and improper construction practices.

Routine crack types are given names according to the patterns which they form. In addition, cracks are normally





classified as to their direction (longitudinal, transverse, random, etc.), depth, and width.

#### 2.3.1.1 Crazing

Crazing cracks are easily recognized by the networks they form on the surface of concrete. In crazing, cracks interconnect to form a pattern of irregular hexagonal areas, similar to that developed by drying mud. For this reason, they are also referred to as map or pattern cracking. In actuality, crazing and map cracking are slightly different.

Crazing consists of very fine, nearly invisible, cracks which form patterns less than 1 or 2 inches in dimension (Figure 2.1). "Map cracking is similar, but the cracks are more visible and the areas surrounding the cracks are larger" (Figure 2.2). [7:38] In either case, these cracks may be unsightly, but they are usually no more than  $\frac{1}{8}$  inch deep. Crazing does not affect the structural integrity of the concrete, and only rarely affects durability. [5:189]



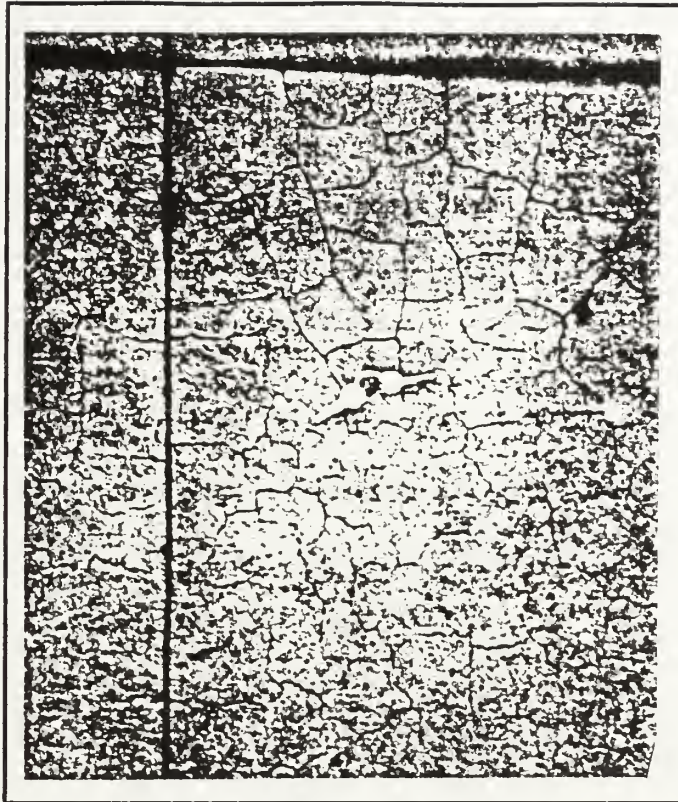

Figure 2.1 Crazing Concrete Surface (Reference 8)

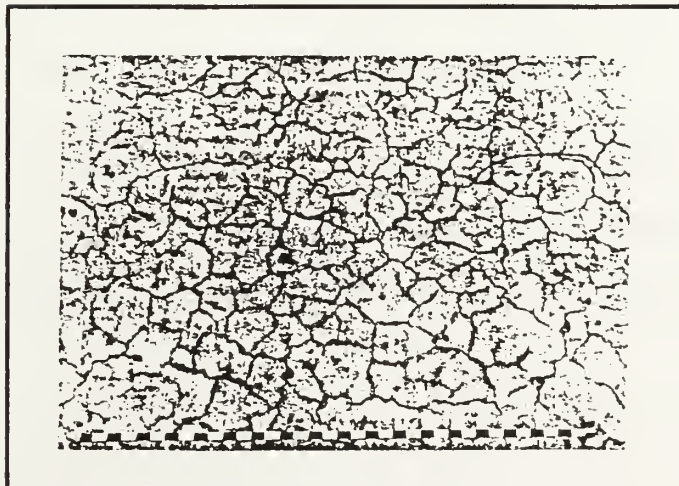

Figure 2.2 Map Cracking (Reference 4)



Crazing normally results "from a decrease in the volume of the material near the surface, or increase in volume of the material below the surface, or both." [4:6] This situation normally occurs because the surface is allowed to dry too rapidly. As such, crazing is usually attributed directly to poor construction practices. The most frequent violations to good construction practice are:

1. Poor or inadequate curing, curing with water colder than the concrete, alternate wet curing and drying, and delayed application of curing compounds can all cause too rapid drying at the surface.

2. Overworking the concrete, including overtrawling, and overuse of jitterbugs, vibrating screeds, and bull floats, can depress the aggregates and bring excessive fines to the surface.

3. Dusting cement onto the surface to dry up bleed water concentrates fines on the surface.

4. Finishing while there is still bleed water on the surface, or water applied to the surface by finishers produces a high water-cement ratio, and a weak surface.



### 2.3.1.2 Early Cracking

Early cracking refers to those cracks which occur shortly after the concrete is poured, while it is still soft or plastic. For this reason, early cracking is often referred to as *plastic shrinkage cracking* (drying shrinkage, which occurs after the concrete hardens and starts to dry out, is discussed in section 2.3.1.3). However, plastic shrinkage is not the only cause of cracks in fresh concrete. "Cracking of the concrete before hardening may result from movement of the forms, subgrade, reinforcing steel or embedded items; settlement of aggregate particles or reinforcing; false setting cement; or sagging or slippage of the concrete, especially on slopes." [8:62] Accordingly, there are two categories of early cracking: plastic shrinkage and settlement. Cracks in both categories may be closed by promptly tamping and beating with a float. However, even if early cracks are quickly repaired, attempts should be made to determine the specific cause of the cracks so that effective preventative measures may be implemented on the remaining construction.

The basic cause of plastic shrinkage is rapid loss of water from the concrete.

As soon as concrete has been placed in the forms, it starts to lose water. Water can be absorbed by a dry subgrade, dry form lumber or dry aggregate; it can be lost through small cracks and openings in the formwork; or it can rise to the surface by bleeding and be lost by evaporation. Of these,





evaporation accounts for the greatest loss of water. Loss of this water causes a decrease in the volume of the concrete...If the loss of water is reasonably slow, the concrete can adjust to the reduction in volume without difficulty, but a rapid loss of bleed water from the surface of the slab will introduce a tensile stress in the surface layer. Because the concrete has no strength, the tension causes cracks. [8:48]

Plastic shrinkage cracks most commonly occur on large surface areas such as slabs. They normally appear during finishing operations or shortly thereafter, before curing starts. Adverse weather conditions, including low humidity, high wind, and high temperature, contribute significantly to the formation of these cracks. Plastic shrinkage cracks rarely affect the strength of concrete slabs. Once the concrete cracks, the stress is relieved, and no further cracking should take place. However, the cracks can be unsightly, and may lead to further problems.

Plastic shrinkage cracks are erratic in their appearance and occurrence, and they normally have no definite pattern (Figures 2.3 & 2.4). "The cracks vary in width from fine hairlines to an eighth of an inch, and in length from an inch to several feet. Depth is seldom more than 2 inches, although the cracks may extend through a thin slab. They may or may not be connected, and ordinarily do not extend to the edges of the affected member." [8:61] Unlike cracks in hardened concrete, plastic shrinkage cracks occur only in the paste surrounding the aggregate. Therefore, early cracks follow around aggregate particles instead of through them, and do not



have the appearance of a clearly defined, clean break. The crack is not a fracture in the hardened concrete, but a separation of the plastic concrete material.

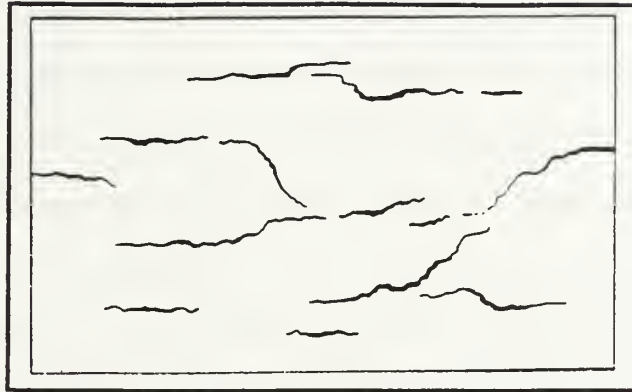

Figure 2.3 Typical plastic shrinkage cracking. (Ref 6)



Figure 2.4 Severe Plastic shrinkage cracks in a floor slab. (Reference 10)



The second category of early cracking occurs from settlement or movement of the concrete in the formwork after compaction and finishing is complete. There are several causes of settlement cracks. *Shifting form cracks* occur if forms are not solidly built. The form does not have to completely fail to cause a cracking problem. Any shifting, slipping or bulging of forms that are not adequately built, or braced, may cause cracking. If the form moves after initial concrete placement, the fresh concrete will move with it, thus creating a crack due to the concrete's low tensile strength (Figure 2.5). These cracks have no particular pattern, but are normally up to  $\frac{1}{2}$  inch deep, and wider at the surface. "Sometimes this crack appears near the form, and at other times further away." [3:72] Like shrinkage cracks, shifting form cracks are unsightly and can lead to further deterioration.

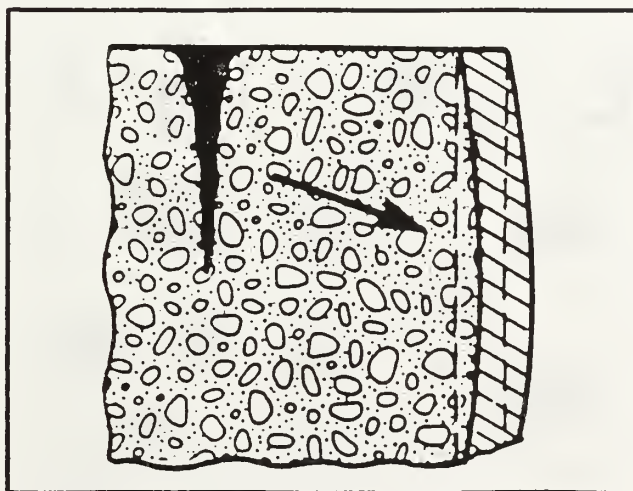

Figure 2.5 Shifting Form Crack  
(Reference 3)



Similar to shifting forms, a subgrade that yields or settles will also cause cracks. These subgrade failures are sometimes referred to as *subgrade paper rupture cracks*. Poor compaction, irregular surfaces, expansive soils, and the presence of mud or soft organic material can all result in a yielding subgrade. Again, there is no pattern to the cracks.

Another type of cracking in plastic concrete occurs because of obstructed settlement. *Reinforcing steel cracks* occur when the concrete settles over reinforcing steel or other embedded items. After initial placement and compaction, the concrete will continue to consolidate. If this consolidation is restrained by reinforcing steel, the concrete gets "hung up" and a crack develops above the restraining element. The crack may penetrate down to the reinforcement, and voids often develop below the reinforcement (Figure 2.6). This type of settlement crack normally increases with increasing bar size, increasing slump, and decreasing cover.

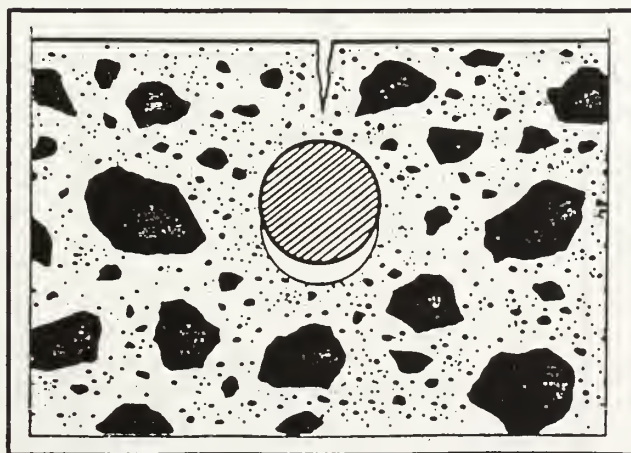

Figure 2.6 Obstructed settlement crack. (Reference 4)





### 2.3.1.3 Post-hardening Cracking

"After the concrete has hardened (that is, after the hydration of the cement has progressed to the point where the concrete has some strength), there are many forces at work trying to damage the concrete. Drying shrinkage, alterations in temperature and moisture, chemical reactions within the concrete, aggressive environment, movement and settlement, freezing and thawing, overloading and accidents, are some of the problems concrete has to contend with." [8:63] Most of these forces are beyond the control of the contractor placing the concrete. These Contractors should mainly be concerned with preventing accidents and overloads, and ensuring proper water content so that drying shrinkage does not occur.

Like plastic shrinkage, drying shrinkage is caused by loss of water from the concrete. When concrete dries, it shrinks. If the concrete were free to move when it shrinks, there would be no shrinkage cracking (Figure 2.7).

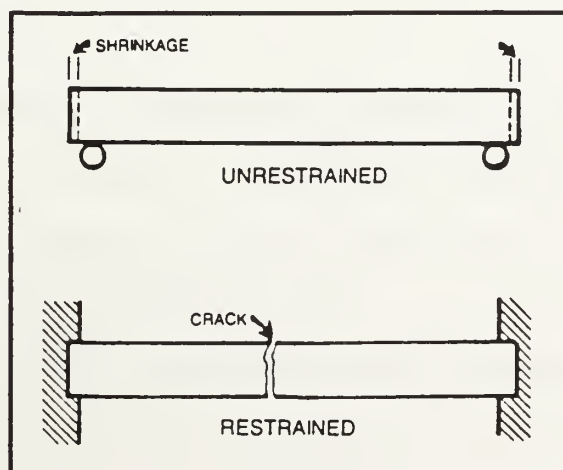

Figure 2.7 Restraint causes drying shrinkage cracks  
(Reference 8)



But all concrete is restrained in some way. Adjacent structures or structural members, the subgrade under the slab, reinforcement, and formwork all prevent the slab from moving freely. Consequently, the concrete cracks. Drying shrinkage cracks usually appear as "random, straight, hairline cracks that extend to the perimeter of the slab...These cracks are shallow and offer no serious problem beyond marring the appearance of the concrete" (Figure 2.8). [3:71] However, drying shrinkage will tend to widen cracks caused by other factors, such as plastic shrinkage.

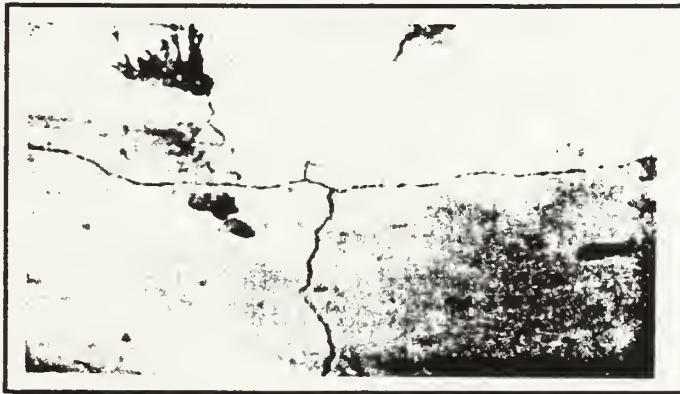

Figure 2.8 Typical drying shrinkage cracks (Reference 3)

The higher the water content for a batch of concrete, the more that concrete will shrink. Therefore, drying shrinkage can be reduced by employing the lowest usable water content, and the maximum practical aggregate amount in the mix. Shrinkage cracking can also be controlled by using properly placed and constructed control joints. These joints create a plane of



weakness so that the concrete will crack at the desired location, rather than randomly.

### 2.3.2 Surface Defects

Regardless of design and specification adequacy, achieving a uniform, blemish-free concrete surface is often difficult. Both formed and unformed surfaces can exhibit undesirable defects such as scaling, dusting, and pits and voids, that mar the concrete's appearance. Some of these defects are strictly related to formed surfaces, while others occur only on unformed surfaces. Since the underside of elevated slabs are formed, and often open to view, both types of defects will be discussed.

#### 2.3.2.1 Scaling

Scaling of concrete surfaces is defined as "local flaking or peeling away of the near surface portion of concrete or mortar" [4:8]. Generally, scaling starts as small patches, which may merge and extend to larger areas. The effect ranges from light scaling, in which only the surface mortar is lost, to very severe scaling, in which the coarse aggregate is lost with the mortar. Light scaling does not expose the aggregate (Figure 2.9).

Scaling is generally attributed to freeze-thaw cycles when moisture is present in the concrete, or to the application of deicing salts on new concrete. However,



improper construction methods will also cause scaling. Any finishing operation performed while there is still bleed water on the surface will lead to a weak surface and possible scaling. Insufficient or improper curing will also lead to a weak surface, and scaling. Thin flakes of concrete may also break away by adhering to the forms when they are removed.



Figure 2.9 Scaled concrete  
(Reference 4)

#### 2.3.2.2 Dusting

Like scaling, dusting is another effect of a weak or soft concrete surface. Dusting surfaces are easily identified by rubbing the hand over the surface--a soft surface will rub off on the fingers. Dusting is especially noticeable on concrete slabs because they will powder or chalk under any traffic, and are readily scratched, even with a fingernail or





broom. Dusting can be caused by any finishing operation while bleed water is still present on the surface, and by inadequate curing. In addition, inadequate ventilation of close quarters where carbon dioxide may be present (from gasoline engines or generators) can cause a chemical reaction known as *carbonation*. This reaction reduces the strength and hardness of the concrete surface. [5:186]

### 2.3.2.3 Blisters

Blisters are defined as "hollow, low-profile bumps on the concrete surface typically from the size of a dime up to an inch, but occasionally even 2 or 3 inches in diameter" (Figure 2.10). [5:197] The blisters can be difficult to see, and may not be detected until they break open under traffic.

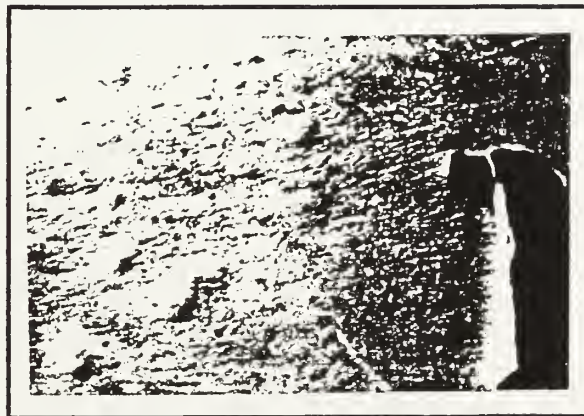
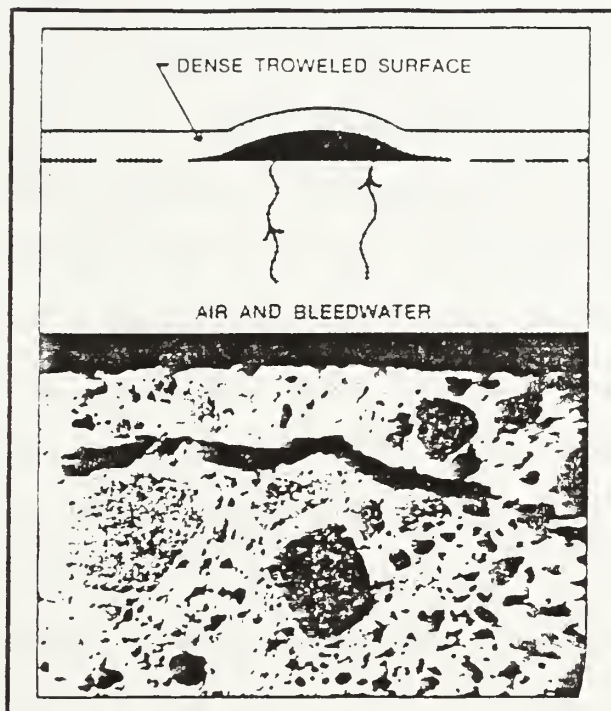

Figure 2.10 Concrete blisters  
(Reference 5)

Blisters can occur when the concrete surface is sealed by trowling, and the underlying concrete is still plastic. By



closing the surface too early, water and air are not permitted to exit the concrete mass. The water and/or air then collect under the surface "skin" to form a void (Figure 2.11).



**Figure 2.11** Concrete blister formation (Reference 5)

Concrete surfaces are often closed too early because they set faster than the underlying concrete. Rapid setting of the surface concrete can be brought about by: too sticky a mix; excessive fines at the surface from overscreeding, overvibration, and excessive or improper floating; and from climatic conditions. [7:39]



#### 2.3.2.4 Spalling

Spalling causes a deeper surface defect than blisters or scaling. Spalls can be defined as "fragments, usually in the shape of a flake, detached from a larger mass by a blow, by the action of weather, by pressure, or by expansion within the larger mass." [9:5] The resulting depression in the concrete surface may be an inch or more deep, often extending down to the reinforcement.

The size of a spall can vary from small, which may be barely noticeable, to large, which create holes over 6 inches in diameter and six or more inches deep. Large spalls may seriously affect the strength and serviceability of concrete slabs. Specific causes of spalls include: insufficient cover over reinforcement, inferior concrete cover which allows the steel reinforcement to corrode, and poor bonding of two-course floors.

#### 2.3.2.5 Popouts

A popout is the breaking away of a small portion of the concrete surface. Popouts are roughly conically shaped, with the base of the cone on the concrete surface, and the point in the concrete. At the tip of the point is usually a particle of some kind which expanded with enough force to break out the concrete (Figure 2.12).



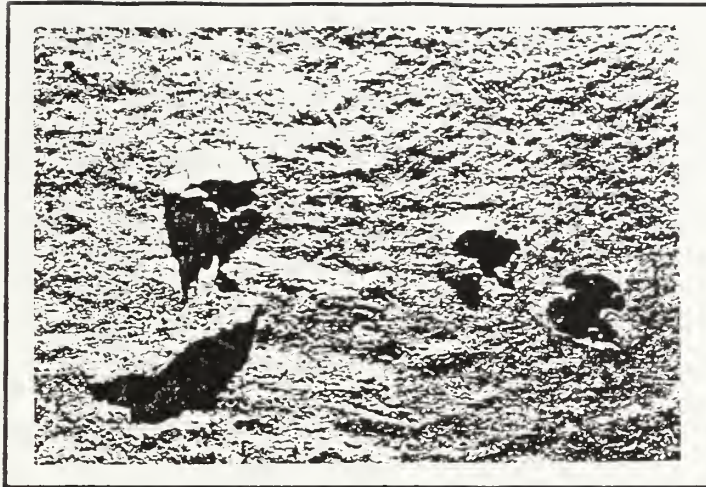

Figure 2.12 Typical popouts  
(Reference 8)

Popout holes typically range in size from  $\frac{3}{8}$  inches to 2 inches in diameter. Popouts may be unsightly, but they normally do not impact the integrity of the concrete. However, if appearance or a smooth surface are particularly important, the popouts will have to be repaired.

The most frequent cause of popouts is impurities in the concrete mix. Soft, lightweight, porous materials can retain moisture and expand when frozen. Other aggregates react with the cement to cause popouts. Since the presence of impurities in the mix is usually beyond the control of the constructor, he should make every effort to ensure that the concrete producer has taken steps to alleviate the problem. Also, the need to follow good construction practices concerning the mix, finishing, and curing cannot be overstressed.





### 2.3.2.6 Honeycombing

Honeycombing is usually considered to be a formed surface defect. As such, this problem is not normally encountered in slab work, unless the slab is elevated, and the underside is formed. Honeycombing occurs when the cement mortar fails to fill all the spaces around the coarse aggregate. It is easily recognized by voids in the surface where the concrete appears as coarse aggregate coated with mortar with no mortar between the coarse aggregate particles (Figure 2.13).

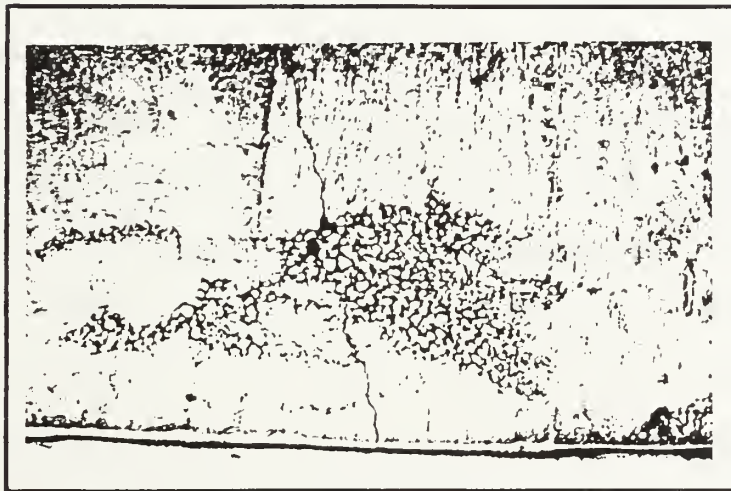

Figure 2.13 Surface Honeycombing  
(Reference 3)

Beyond its unsightly appearance, honeycombing can severely weaken an area of concrete. This problem can be especially troublesome when the honeycomb is not obvious, but within the concrete member (Figure 2.14).





Figure 2.14 Honeycombing within concrete (Reference 4)

Honeycombing is caused by lack of consolidation or compaction of the concrete in the forms. When the concrete is first placed in the forms, it contains entrapped air. Failure to consolidate the concrete thoroughly through vibration, will cause voids in the concrete. Honeycombing can also be caused by loss of cement mortar through leaking forms, and by segregation of the concrete from overly fluid mixes. Segregation also occurs from improper handling, and excessive coarse aggregate in the mix. [8:73]

### 2.3.3 Joint deficiencies

Joints are placed in concrete to allow movement, and minimize cracking or cause the concrete to crack in a desired location. However, failure to properly place and construct the joints can result in unwanted problems, and can shorten



the life of the slab. In addition, even proper joints can exhibit deterioration, wear and deformation, especially if they are not maintained. Typical problems that occur at joints include: corner failures, joint separation, joint spalling, joint failure, and faulting or stepping. These problems are self-explanatory, or have already been characterized above, and no detailed description is required.

All of the joint deficiencies can be attributed to a few common causes. Any slab is only as good as the base on which it rests. Therefore, a weak base, or a base which is allowed to weaken over time, will contribute to joint failure. Lack of sealant material will allow water to reach and erode the base, and allows the joint to fill with other foreign matter which can expand and cause the joint to fail. Improper joint materials or construction may inhibit the desired movement and eventually result in cracks or faulting. Spalling may result from poor timing in sawing control joints.

Spalling also results from hard-wheeled material handling equipment crossing the joint, or from other impacts. Metal keys left in place create a concrete "nose" that can break off. As wheels continue to cross over the joint, the metal key continues to strike the joint edge and cause further damage (Figure 2.15). In addition, in those cases where a joint is sealed with elastomeric material, the joint can spall because the sealant only keeps out dirt and moisture, and does nothing to protect the joint from impact (Figure 2.15).



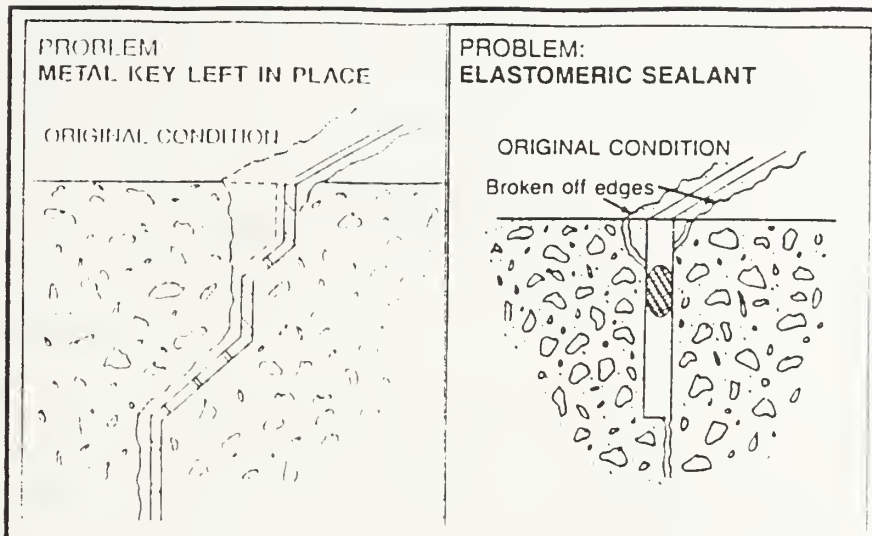

Figure 2.15 Causes of joint edge spalling (Reference 20)





## CHAPTER III GENERAL REPAIR PRINCIPLES

### 3.1 Overview

In spite of precaution and quality control during the mixing and placing of concrete, there are occasions when damage or defects occur. Before proceeding with any repairs of these problems, an evaluation should be made to determine the location, extent, and cause of the problem, and the need for repairs, regardless of the age of the concrete. The key to successful, long-lasting repair of concrete problems is to implement and follow a repair program which takes into account these considerations. A solid repair program should include the steps necessary to evaluate the problem, choose a repair method and material, prepare the surface, and complete the repair.

### 3.2 Evaluating Concrete Problems

Whenever a question is raised regarding the significance of concrete defects, an evaluation of the structure or member should be performed first. A thorough review will give clues as to the cause of the defect, and will help to decide what action, if any, should be taken. "Selection of a repair program must be based upon a full assessment of the concrete



condition and its interaction within the structural system and facility type. Failure to follow the above guideline may place the engineer at considerable risk by generating a program poorly suited to the structures needs." [11:6]

To properly assess a structure's condition and determine the best repair solution, the evaluating engineer should perform the following steps:

1. Initial preparation - to include a review of the drawings, construction records, and any other background information.
2. Preliminary inspection - to visually inspect and document the location, extent, and severity of any obvious problems. During this work, sketches should be made and photographs taken to document all problems found.
3. Detailed inspection - Non-destructive testing to determine the presence of internal problems, and the depth of cracks or other defects visible at the surface.
4. Further investigation - if necessary, cores can be taken for further examination.
5. Diagnosis - identification of the problem and its cause.

The combination of these five steps is generally referred to as the *Condition Survey*. For older buildings, these surveys may become quite detailed and complicated. However, for



buildings under construction. the survey can most times be completed fairly easily, without the need for destructive testing. In either case, it is important to stick to the system developed for evaluating problems, so that unusual or hidden causes are not overlooked.

The American Concrete Institute (ACI) publishes several guides to assist engineers in evaluating concrete problems. ACI 201.1R-68, Guide for Making a Condition Survey of Concrete in Service, and ACI 201.3R-86, Guide for Making a Condition Survey of Concrete Pavements (Appendix A) both provide excellent systems for investigating concrete problems. ACI 309.2R-82, Identification and Control of Consolidation-related Defects in Formed Concrete (Appendix B) provides guidance for evaluating and preventing surface defects. In addition, guidance on examining and sampling concrete in construction may be found in ASTM C 823. The ACI guides also outline the records which should be kept **during construction** to facilitate repairs, if they are needed, at any time during the life of the structure.

### 3.3 Choosing a Repair Method

Based on the diagnosis of the problem from the condition survey, a repair procedure may be selected. Depending on the type and extent of damage, several methods may be available for use. Cracking, for example, can be repaired by stitching, injection, routing and sealing, grouting, drilling and



plugging, drypacking, overlays, and other methods. The repair method decision is important, as choosing the wrong method may result in a worthless repair, and much unneeded effort.

Beyond the extent and cause of the problem itself, those contemplating concrete slab repair should also consider the ability of the surrounding concrete to support the repair, the intended function of the slab, the objectives of the repair, the difficulty involved, the time allowed for the repair work, the expertise required, and the cost. Unfortunately, cost is often the driving factor, as limited funds usually allow only less expensive or temporary repairs. These repairs frequently address only the effect, and not the cause.

The key factor involved in method selection should be the objectives of the repair. "...Procedures can be selected to accomplish one or more of the following objectives:

1. Restore or increase strength;
2. Restore or increase stiffness;
3. Improve functional performance;
4. Provide watertightness;
5. Improve appearance of the concrete surface;
6. Improve durability; and/or
7. Prevent access of corrosive materials to reinforcement." [6:11]

With a definite objective in mind, a specific repair method can be chosen. Aside from the profusion of proprietary repair methods and materials, the range of repair methods is fairly





limited. The basic repair methods are: concrete replacement, patching, overlays, sealing, shotcreting and injection.

### 3.4 Choosing a Repair Material

The nearly unlimited choice of specialized repair products makes choosing the right material for the job difficult, but important. "The proper selection of materials for a repair program is normally more involved and important than it is for new construction." [11:6] Repair products on the market today represent a wide range of properties, quality, difficulty of use, and cost, and it is not always necessary to choose the most expensive product.

The useful life of any concrete repair work will depend on the skill of the craftsmen and the quality of their work, the conditions to which the repair is exposed, and the location of the repair in the structure. "The choice of the repair material to be used will depend not only on the particular nature of the problem but also on the function of the structure, the availability of equipment and skilled manpower, the relative importance of appearance, and of course the funds available for the repair." [3:111] When selecting a repair material, a contractor should consider the type of material required, and the properties of that material.



### 3.4.1 Material Types

For simplicity, concrete repair materials may be classified into two groups: cementitious and polymers. The cementitious types are those sand and cement mixtures which only require the addition of potable water. Polymers are those materials which require the addition of one or more components (typically called setting agents) other than water. Both types of materials have their own advantages and disadvantages. [1:152]

Cementitious materials used in repair will most nearly resemble the in-place concrete material in composition and physical properties. These materials can be either proportioned and mixed on site, or purchased as prepackaged products. Cementitious materials have been employed for many years, and require no special skills or expertise to be effectively used. They are much more "user-friendly" than the polymer type, and most contractors have considerable experience with them. With the addition of admixtures such as polymers, cementitious materials can be created which have a wide array of chemical and physical properties.

Polymers are complex substances that require the mixing of two or more chemical components to produce a material which hardens quickly, adheres well, and gains strength rapidly. "These materials are often referred to as 'resins', and the principle resins used in the construction industry are epoxide, polyurethane, polyester, acrylic, polyvinyl acetate,



and styrene-butadiene." [10:25] Polymers require some skill and experience to be used effectively. Because they harden quickly, they can be difficult to work with. Polymers also display varying levels of toxicity and flammability, and must be used with caution.

### 3.4.2 Material Properties

When evaluating alternative repair materials, several material properties should be considered. *Bond strength* is probably the single most important property of the repair material. Most repairs that fail do so because of the lack of adequate bond between the repair material and the substrate. This failure often results in the entire repair "popping out", or flaking off. In fact, the increased development and usage of polymers over the years has been primarily due to their superior bonding capability.

It is essential to obtain the best possible bond at the interface between existing concrete and mortar or concrete used for repair, and prior to the introduction of polymer bonding aids, it was the practice either to use nothing and rely on the preparation of the surface of the base concrete, or to use a cement slurry. Both of these techniques gave excellent results in the laboratory, but in the field, the results were often disappointing...

It must be appreciated that the bond at the interface between the concrete and the repair material is likely to be subjected to considerable stress arising from changes in moisture content, freeze-thaw, a wide temperature range, as well as the force of gravity, and sometimes vibration. [10:20]



Another essential property of a repair material is its ability to resist thermal movement. Any length change through shrinkage or expansion is likely to create cracking and/or debonding.

In most cases, whether using cementitious or polymer materials, the strength of the repair material will be equal to or greater than the concrete to be repaired, and there is no real advantage in specifying a repair product based solely on its strength. However, in those instances where the repair material is expected to contribute to the strength of a structure, the required strength should be specified.

Other properties of the repair material which should also be considered are its:

1. modulus of elasticity;
2. creep characteristics;
3. rate of strength gain;
4. durability;
5. consistency, workability, and speed of application;
6. permeability; and
7. chemical resistance.

Finally, although one, or several of these properties may represent the vital factor in deciding on a particular repair material, the all-around performance of the material for the situation at hand must also be examined. This examination should include the materials' compatibility with other





materials used in the repair. In general, polymers should be used where a thin repair section is required. For larger repairs, cementitious materials are preferred because of their lower cost, greater compatibility with the existing concrete, and better workability. In either case, it is always advisable to contact the material manufacturer to discuss specific properties, uses, and installation requirements.

### 3.5 Preparations for Repair

After the condition survey has been completed, and the repair method and material chosen, the area to be repaired should be checked again to ensure all damaged or defective areas are marked for repair. "No matter how carefully the investigation has been carried out it will not have revealed all the areas of defective concrete; in fact it was not intended to do this, but to establish the cause and general extent of the deterioration and provide the information needed to prepare a specification for the remedial work." [10:91] When all areas requiring repair have been marked, the surface must be prepared for execution of the repairs.

The condition of the surface to accept the repairs is just as important as the selection of the repair material. A properly prepared surface is essential to provide good adhesion and support for the repair material, and to ensure a long lasting repair. "Regardless of the repair product selected, the success of the project will depend not only on



the material used, but also on the preparation of the area to be repaired." [3:102] A poorly prepared surface will become the weak link in any repair.

Surface preparation requires a systematic approach which can evaluate the existing condition and prepare the surface for the specific repair material to be used. Merely providing a "clean and dry" surface is insufficient, as these terms are open to interpretation, and the surface must also be strong enough to support the repair, and must not be smooth. In general, the recommended procedures for proper surface preparation include:

1. Sawcutting around the area to be repaired. Minimum sawcut depth is 1 inch, but 2 inches is preferred.
2. Removal of all loose material, and any weak, defective concrete. This work can be accomplished by hand chipping, pneumatic tools or high velocity water jets. Care should be taken to ensure that the use of pneumatic tools does not create additional cracks in the surface.
3. Removal of all detrimental substances including oil, grease, dirt and curing agents. Water or sand blasting work well, but chemical cleaners such as acids and/or degreasers can be used. However, all acids and degreasers must also be thoroughly removed. Grinding should be avoided, as it leaves the area too smooth.
4. Cleaning to bright metal any reinforcement which is uncovered, especially if using polymers in the repair. This step is normally accomplished by sandblasting.
5. Roughening the surface to improve adhesion. Mechanical means such as chipping or bush-hammering may be used. Acids which remove the cement paste down to the fine aggregate are also effective.
6. Final cleaning of the repair area with compressed air immediately prior to repairs, to ensure that the surface has not become soiled, and all fine dust is removed.



## CHAPTER IV MATERIALS AND METHODS OF REPAIR

### 4.1 Overview

Good repairs can always be made by following the fundamentals of thorough preparation, using quality materials, and proper application methods. General information on selecting repair materials and methods, along with guidelines for surface preparation were provided in Chapter III. This chapter will describe in detail the properties and uses of the major repair materials available on the market today. It will also discuss the methods used to repair concrete slab defects and damage.

### 4.2 Materials

There are many materials available today to repair concrete. The most commonly used are cement-based concretes, and mortars, but resin-based materials such as epoxies and polymer concretes have also seen widespread use. Other proprietary materials are also constantly being developed and placed on the market. Many of these proprietary materials are good, but some are suspect and their effectiveness remains to be proven. New materials add an extra variable to the repair, but reliable manufacturers should freely give information on



the use and composition of their products. Users should also check independent laboratory test results and the history of use of the product under similar circumstances. Criteria for selecting a repair material is provided in section 3.4.

#### 4.2.1 Cementitious Materials

Cementitious repair materials are made with the same cement and aggregates used in concrete construction, and they achieve physical properties very similar to concrete. "Requirements for repair concrete are generally the same as for original construction except for restrictions to limit traffic obstruction time and to minimizing differential volume changes." [12:145] Cementitious materials have the advantages of being well known, readily available, and reasonably low in cost. The main disadvantage of cementitious materials (used alone) is their lack of adequate bond strength.

The design of a cementitious mix can be changed to accommodate almost any repair situation. The considerations which dictate the mix design are the depth of the repair, and the workability of the mix. "The maximum size of the coarse aggregate should be about half the thickness of the resurfacing. The mix should be workable--at a water-cement ratio of not more than 0.45." [3:301] In addition, where exposure to freezing and thawing is anticipated, the concrete should be air entrained.





Special cements are often used to modify the mix as required. High alumina cement and rapid hardening cements can be used to adjust the setting time and rate of strength gain. Sulphate-resisting and other chemically resistant cements can be used where chemical impregnability is required. Even colored cements can be specified where the appearance of the repair is important. In addition, admixtures can be used in the mix to improve its bonding capability, strength characteristics, and chemical resistance. The most common materials of this type are latex modified concrete, and polymer concrete.

Cementitious materials can also be used in conjunction with a separate bonding agent to improve the bonding between the newly placed cement-based material and the existing concrete. In fact, for shallow depth patches and thin overlays, a bonding agent is recommended. Bonding agents may consist of portland cement grout, latex modified cement grout, or an epoxy system.

#### 4.2.2 Polymers

While cementitious materials are the older, and more widely used repair materials, new products are being increasingly used for repair and protection of buildings constructed from traditional materials. The major area of new material development is that of synthetic polymers such as epoxies, polyurethanes, polyester, latexes, and polyvinyl



acetate. These chemical compounds have not replaced traditional repair materials, but their types and uses have become widespread, especially where special benefits or specific material properties are required. [13:392] "While the range of use of these materials is very wide, it is convenient and practical to divide it into two main categories; namely, coatings in which the formulated compound is used on its own, and mortars and concretes in which the resin is mixed with aggregate and sometimes cement." [10:25]

#### 4.2.2.1 Resins/Polymers/Adhesives

The term *resins* refers to materials which are chemical compounds, derived mostly from the petrochemical industry (the term is often used synonymously with *polymers*). There are many types and formulations of resins. As stated, these can be used alone, or combined with mortar mixes. For the purpose of this report, the term *adhesive* will be employed for those polymers which are used alone. The term *polymer concrete* will be used when the polymer is combined with a mortar mix.

Adhesives are normally made of two components, consisting of the basic resin, and an accelerator (sometimes called a hardener). The two components must be mixed immediately prior to their use. Some of the more important considerations relating to mixing and using resins are:



1. *Pot life.* This is the amount of time which can elapse between mixing the resin components, and applying the resin where needed. This time can be varied by the formulator, but it is normally fairly short. Therefore, only the amount of material which can be applied within the pot life should be mixed at one time.

2. *Hardening.* This is the time required for physical setting of the plastic resin after application. It can also be varied by the formulator of the resin.

3. *Curing.* This is the time when the molecular linkage of the resin takes place, and the resin gains strength and durability. The average curing time, depending on ambient temperature, is 7 days. This time can also be varied. [10:27]

The oldest and most widely used adhesives are the epoxies. There are literally hundreds of compounds, now on the market, known as epoxy. To help avoid confusion, ASTM Standard C 881 provides requirements for three types, three grades, and three classes of epoxy for use with concrete. Type I epoxies are those designed for bonding hardened concrete to hardened concrete, as in the case of crack repair. Type II epoxies are for bonding freshly mixed concrete to hardened concrete, as in spall repair and patching. Type III epoxies are for bonding skid-resistant materials to hardened concrete. Epoxy grades are based on consistency and viscosity, while the classes are based on ranges of temperatures for which the epoxies are suitable for use (table 4.1).



Table 4.1 Grades and classes of Type I epoxies

Grade 1	Maximum viscosity	20 poises
Grade 2	Minimum viscosity	20 poises
	Maximum viscosity	100 poises
Grade 3	Consistency, maximum	$\frac{1}{4}$ inch
Class A	For use below 40 degrees F	
Class B	For use between 40 & 60 degrees F	
Class C	For use above 60 degrees F	

(Reference 14)

Besides viscosity and temperature range, epoxies can be custom formulated to obtain a wide range of properties to meet specific, specialized needs, or for general use. These properties include the ability to cure at very low or high temperatures, the ability to cure under moist conditions, low to high modulus, and chemical resistance. Epoxy resins have seen increased usage in the concrete repair area because they have a much greater bond strength and quicker strength development than cementitious products, and their curing shrinkage is extremely small.

Polyurethanes are also resins that are commonly used on their own for concrete repairs and protection. These adhesives can be obtained as elastomers (any elastic, rubberlike substance), rigid materials, and as flexible coatings. Like epoxies, polyurethanes are very durable, and can be formulated with varying properties to meet specific





requirements. One important characteristic of polyurethanes is that they will cure in temperatures below freezing, while epoxies cannot be relied on to cure below 40° F.

#### 4.2.2.2 Polymer Concrete

A relatively new, but widely accepted repair material is resin mortar. These materials, commonly referred to as polymer concrete, essentially consist of mineral aggregates bonded by resins. "...Polymer concrete is concrete in which the cement is replaced either entirely or principally by an organic polymer such as epoxide or polyester resin, or normal concrete which contains polymer as an additive." [10:29] Concretes and mortars containing these materials have "several advantages over their cement based counterparts that include rapid strength development, superior compressive and tensile strengths and good adhesion to both steel and concrete substrates." [13:478]

Many materials are used to make polymer concrete including epoxies, polyesters, methyl methacrylate (MMA), and synthetic latexes such as acrylics, polyvinyl acetates (PVA) and styrene-butadiene. The most successful polymer concretes have been those that use epoxy formulations or MMA. However, latex modified concrete (LMC) has enjoyed increased popularity in the last several years.

Epoxy concrete generally consists of an epoxy system with aggregate as recommended by the epoxy formulator. The most



commonly used aggregate is silica sand, with mortars consisting of 4 to 7 parts sand to 1 part resin, and increased ratios for the larger aggregates used in concrete. The maximum aggregate size should be no more than  $\frac{1}{8}$  the thickness of the repair. Accurate batching and proper mixing of all these components are essential, and should be performed as recommended by the manufacturer. [12:151] Epoxy concrete is normally used for patching and overlays. It has many advantages over normal concrete including greater durability and resistance to wear, a lower absorption rate, greater flexural and tensile strength, and resistance to impact loads.

Methyl methacrylate (MMA) polymer concrete has been in use for over 20 years. This polymer concrete consists of aggregate and a monomer (liquid) which is polymerized (solidified) in place. These components of MMA can be formulated by the user, or a pre-packaged system can be used. The pre-packaged systems contains the fine aggregate coated with polymers, the monomer component (MMA), initiators, and pigments. "Initiators are materials required to start polymerization and promoters are chemicals to accelerate polymerization." [12:152] When MMA systems are formulated by the user, the initiator and promoter must be added.

There are several different MMA systems, each suited for a particular application. MMA polymer concrete has about the same modulus of elasticity and coefficient of thermal expansion as normal concrete, making it an ideal repair



material because the stresses it exhibits are similar to normal concrete. Additionally, "MMA has many advantages over conventional concrete, including among others, rapid setting, ease of use, usability in hot and cold temperatures and water and salt resistance." [13:398] MMA can be effectively utilized for thin and deep spall repairs, full depth repairs, and both thin ( $\frac{1}{4}$ "-1") and thick ( $1\frac{1}{4}$ "-2") overlays.

Latex modified concrete (LMC) consists of a portland cement mortar or concrete with the addition of a synthetic latex modifier such as styrene-butadiene. Synthetic latexes are plastic particles (polymers) suspended in water. These fluids are manufactured with varying percentages of solids, and are added to standard concrete to produce a mix with superior durability and bonding characteristics. Selection of the latex modifier should be based on anticipated service conditions, as each particular modifier will influence the strength and durability of the concrete differently. [12:149]

In concrete repair work, LMC is most often used for patching and overlays, especially on bridges and parking garages. Patches made with LMC may be made in thicknesses greater than  $\frac{1}{2}$  inch, but are not recommended for thinner repair sections. A minimum thickness of  $1\frac{1}{4}$  inches is preferred for overlays.

With the many advantages polymer concretes have over cementitious repair products, they would seem to be an ideal repair material. Yet, polymers also have their disadvantages.



Their short pot life and rapid hardening may produce placement and cleanup difficulties. As with most chemicals, polymers are volatile, flammable and can be toxic. In fact, MMA initiators and promoters can explode if mixed directly together. As with normal concrete, polymers require special attention during curing to ensure the material reaches its full potential in strength, bonding and durability. Lastly, polymers are very expensive. A study completed in 1982 found the extra cost of polymer concretes could be as high as: \$325/yd<sup>3</sup> for LMC; \$600/yd<sup>3</sup> for epoxy concrete; and \$1000/yd<sup>3</sup> for MMA (table 4.2).

**Table 4.2** Extra material cost/sq. foot of overlay (1982)

	<u>Overlay Thickness (in)</u>			
	<u>1/2</u>	<u>1</u>	<u>2</u>	<u>3</u>
LMC	--	\$0.89	\$1.78	\$2.67
Epoxy	--	\$1.50	\$3.00	\$4.50
MMA	\$1.30	\$2.60	\$5.20	\$7.80

(Reference 15)

#### 4.3 Methods of Repair

Concrete can fail as a result of many different causes including: physical or mechanical forces; corrosion and chemical attack; improper design, production, and construction; and forces or chemistry within the concrete itself. The results of these various causes manifest





themselves in many different forms. Because of these two facts, every concrete problem has unique characteristics, and consequences of repair.

To ensure an effective repair, each concrete problem should be evaluated according to its own set of circumstances, and a specific repair method and material determined. In general, the contractor performing concrete slab repair must be familiar with the methods required for patching and small scale repairs, concrete replacement, repairs to joints, and repairs to cracks. Prior to commencing any of these repairs, the surface should be properly prepared as outlined in chapter 3 (section 3.5).

#### 4.3.1 Patching and Small Scale Repairs

Patching is the preferred method for repairing small isolated spall areas, and other surface defects such as holes, blisters, shallow honeycombing, and popouts. The size of the spall and the condition of the surface control repair material selection. Small spalls and voids, where bond and shrinkage are not as critical, can be filled with a straight cement mortar. Larger spalls can be repaired with normal concrete, dry pack mortar, preplaced aggregate concrete, or polymer concrete. If normal concrete is used, a bonding agent should be applied first. Shotcrete can also be effective for making shallow repairs, especially on the underside of overhead slabs.



"The dry pack method consists of ramming a very stiff mix into place in thin layers." [17:32] Because concrete shrinks as it dries, dry pack mixes are prepared with just enough moisture to be workable. Slump for these mixes should not exceed 1 inch, but no slump is preferable. "Practically no shrinkage will occur with this mix, and it develops a strength equalling or exceeding that of the parent concrete." [17:32] This method does not require any special equipment. The dry pack mortar should be forced into the hole, then compacted with hand tamps to ensure it is packed tightly. The surface is then levelled off, and cured by fog spraying or covering with wet cloth or burlap.

The preplaced aggregate method utilizes normal aggregate with a polymer binder. In this method, the aggregate is premixed, then placed into the hole and screeded to the required level. The components of the polymer (a monomer and an initiator) are then thoroughly mixed together and poured over the aggregate. The patch should then be consolidated by tamping or vibration, taking care to avoid segregating the aggregate from the liquid polymer. After the liquid polymer has filled the patch area and ponded on the surface, screeding is performed to level the surface. Sand should be added to avoid a slick surface. Polymers are volatile, so the surface should be covered to avoid evaporation losses.

Any of the polymer concretes reviewed in section 4.2.2.2 can be used for patching. Surface preparation is the same as



for normal concretes, but curing is much faster so the slab may be returned to service earlier. Because of their improved bonding, reduced shrinkage and permeability, and increased strength and durability, Polymer concretes are recommended over normal concrete.

Small scale repairs include the removal of small surface protrusions, and filling of air holes. Protrusions such as surface fins, bumps, and blisters can be removed by grinding, mechanical impact, or rubbing with a carborundum stone. Air holes can be filled with a mortar consisting of 1 part sand, and  $1\frac{1}{2}$  parts sand, when the concrete is more than a day old. [16:293]

#### 4.3.2 Concrete Replacement

The concrete replacement method consists of replacing all defective concrete with new concrete which is similar to the old in maximum aggregate size and water-cement ratio. The new concrete becomes integral with the base concrete. A considerable amount of concrete removal is required for this type of repair. Faulty concrete should be removed until sound concrete is reached, but the complete removal of concrete should always be a last resort. There are occasions when complete removal is required, such as a badly damaged slab, but most concrete slabs can be repaired without replacing the entire slab.



"Concrete replacement is the desired method if there is honeycomb in new construction or deterioration of old concrete which goes entirely through the wall or beyond the reinforcement, or if the quantity is large." [17:32] If honeycomb is found in new work, the replacement should be made immediately after stripping forms. Forming is often required on large scale repairs, and it is sometimes necessary to pump the concrete into the form.

#### 4.3.3 Repairs to Cracks

There are many methods available to repair cracks in concrete slabs. Epoxy injection, flexible sealing, drilling and plugging, and grouting are only a few of the methods which are being used today. Selecting the right method for the situation at hand is important, but equally important is the evaluation of the conditions which have caused the concrete to crack, and the abatement of those conditions. "The proper repair of cracks depends on knowing the causes and selecting the repair procedure that take these causes into account; otherwise, the repair may only be temporary." [6:1]

Another factor pertaining to crack repair is knowing when to repair the crack, when to replace the concrete, and when to leave the crack alone. "Only cracking that may potentially endanger the structural adequacy of the member should be considered for repair. Many cracks do not require repair, some cracks cannot be repaired." [12:142] An exception to





this "rule" is the repair of cracks for appearance or serviceability reasons. Cracking, for example, has no corrective treatment, nor is one required unless the owner absolutely cannot live with its appearance. In that case the concrete would have to be replaced or resurfaced.

In response to the uncertainties of determining when cracks should be repaired, the ACI established tolerable limits for crack widths in reinforced concrete. The tolerable limit depends on the prevalent exposure condition (Table 4.3). When crack widths exceed the tolerable width, repairs should be implemented.

**Table 4.3 Tolerable crack widths**

Exposure Condition	Tolerable crack width (inches)
Dry air or protective membrane	0.016
Humidity, moist air, soil	0.012
Deicing chemicals	0.007
Seawater and spray: wetting and drying	0.006
Water retaining structures*	0.004
*Excluding pressure pipes	

(Reference 18)

For comparison, cracks become visible with the unaided eye at about 0.004 inches. At about 0.02 inches the separation between the two edges of a crack may be just visible. While these size cracks can be estimated by eye, it is advisable to use a crack gauge, or an optical instrument to determine a precise crack width.



ACI 224.1R-89, Causes, Evaluation, and Repair of Cracks in Concrete Structures (Appendix C) summarizes the causes of cracks, describes evaluation techniques. discusses the common methods of crack repair. An in-depth analysis of the epoxy injection method is provided in the section 4.3.3.2 of this report. The reader is referred to appendix C for information on other crack repair techniques.

#### 4.3.3.2 Epoxy Injection Repairs

Epoxy injection has become one of the most common ways of repairing narrow cracks. It has been used successfully in the repair of all types of concrete structures. Epoxies can be injected as far as 9 feet deep into cracks as narrow as 0.002 inches. [19:45] Additionally, the superior properties of epoxy will permit the repaired crack area to exceed the strength of the surrounding concrete. These attributes would seem to make epoxy injection the perfect crack repair method. But epoxy cannot solve every crack problem. Active cracks (those that continue to close or open) cannot be repaired unless the underlying cause is first removed. Although epoxies can be formulated to be insensitive to water, epoxy injection does not work well if the crack is contaminated, or if the cracks cannot be dried out. "While most cracks can be injected, contaminants in the crack, including water, will reduce the effectiveness of typical epoxies." [19:45]



When choosing an epoxy for crack repair, a contractor should consider the epoxy's type, viscosity, moisture sensitivity, pot life, and minimum curing temperature. Type I epoxies (see section 4.2.2.1) should be used for all crack repair. The viscosity requirement will depend on the type of crack considered for repair. Narrow crack repair requires a low-viscosity epoxy which can penetrate deeply with ease. Wide cracks may allow low-viscosity epoxies to seep out through a porous subgrade, or may create too large a volume of epoxy, which can produce enough heat to cause the epoxy to boil and froth. Wide cracks require a higher viscosity epoxy, or a flowable epoxy mortar.

The procedures for epoxy injection are not complicated, but they do require special equipment and a high degree of skill to obtain satisfactory results. The basic procedure is to inject the epoxy into holes drilled at intervals along the crack. The epoxy may be applied through gravity, hand operated pressure guns, low-pressure spring-actuated pumps, or high-pressure injection equipment. Regardless of the equipment, what is required with all crack injection is uniform penetration and complete filling of the crack.

Specifically, the injection procedure requires these steps:

1. Clean out the crack. Contamination can be removed with high-pressure water or air (if water is used, allow for drying time). At least a 1 inch strip on each side of the crack should also be cleaned of all contamination to ensure adequate bond of the surface



sealer. Avoid getting any dust in the crack if grinding equipment is used to clean the edges.

2. Seal the surface. The "cap" over the crack acts like a form to contain the epoxy, and is not an integral part of the repair. Selection of the cap material depends on the injection system. Low pressure systems can be sealed with wax, while high pressures require an epoxy adhesive. The material should also have a fast cure time so that sealing and injection can be accomplished on the same day. Avoid creating any skips or thin spots in the cap where epoxy material could later leak out.

3. Install the injection ports. Low-pressure systems may simply use an interruption in the seal. Higher pressures require an injection port bonded to the surface over the crack, or fittings inserted into drilled holes and bond with epoxy adhesive. Proper spacing of the ports is important. In general, the smaller the width of the crack, the closer the injection ports should be spaced. "As a rule of thumb, the entry ports should be spaced at a distance equal to the desired penetration of the epoxy but not exceeding the thickness of the concrete or 12 inches, whichever is less." [19:49]

4. Mix the epoxy. It is important to batch and mix the epoxy properly, as improper batching will affect the epoxy's final properties. Only that amount of epoxy that can be used prior to the onset of the material gelling should be mixed. "When the adhesive begins to gel, its flow characteristics begin to change, and pressure injection becomes more difficult." [6:13]

5. Inject the epoxy. For horizontal cracking, there is no fixed order of injection. The key to successful injection is selecting the right injection pressure. Excessive pressure can cause further damage, too low pressure and the crack will not be filled completely. When the pressure can be maintained, the crack is full. If the pressure cannot be maintained, the epoxy is still flowing, or there is a leak in the cap. Sometimes, epoxy may also drain into the ground. To correct this problem, the crack must be reinjected until it remains full. This can be a costly requirement. However, the problem is not as severe in narrow cracks, and for wider cracks, the base of the crack can be injected with a silicon sealer, or an epoxy grout can be used.





6. Remove the cap. This can be expensive. If appearance is not a problem, leave the cap on place.

7. Evaluate the repair. For normal repairs, visual monitoring of the crack area should suffice. In more critical repairs, ultrasonic equipment can be used during the injection, or random cores can be taken after hardening, to verify crack filling. Permeability and hardness tests can also be performed on the epoxy.

Epoxy injection can be a highly effective repair method. With on-site support from an epoxy supplier, most routine repairs should be satisfactory. But the process can be quite technical, and the more sophisticated repairs should be left to the specialist. "Epoxy injection can be an easy and effective way to repair cracks, but if done wrong the bad repair may be irreparable. There's simply no easy way to remove epoxy from cracks." [19:49]

#### 4.3.4 Repairs to Joints

Over the life of a concrete slab, one of the most troublesome repair problems is that of damaged, deteriorated, or defective joints. Think of driving over any concrete highway. The constant ka-thunk of the tires running over problem joints emphasizes this point. Although joints are subject to many problems over their service life, the main difficulty the construction contractor will face is joint spalling.



When performing joint repairs, the contractor should keep in mind the following four principles [20:548]:

1. Re-establish a smooth surface; A smooth surface at the joint will help to ensure that future traffic does not cause impacts to the joint area and additional spalling.
2. Don't weld slab units together; Use of a rigid adhesive in joint repair will "lock" the two slabs together. If the concrete is shrinking, "gluing concrete together at the joints can cause a chain reaction of shrinkage related stress. Either the other joints will open wider or cracks will occur between the joints." [20:551]
3. Keep repairs as narrow as possible; Wider repairs are subject to greater exposure and possible failure.
4. Don't featheredge repairs; Although many manufacturers say their epoxies can be featheredged to zero, it is much better practice to notch the repair with a saw cut at least 1 inch deep.

Implementing these principles will ensure a long-lasting joint repair. Specific repair procedures for a spalled joint normally include cutting away the spalled area on both sides of the crack, removing all material inside the sawed-out area, and filling the area with repair material. In most cases, a semi-rigid epoxy mortar is best for repairs up to  $1\frac{1}{2}$  inches wide. For wider repairs, a higher strength epoxy can be used, or a plastic strip can be used to prevent shrinkage stress.



## CHAPTER V CONCLUSION AND RECOMMENDATIONS

### 5.1 Conclusion

When defects, damage or deterioration are encountered in a concrete structure, repair of the problem areas is usually a viable option. Concrete structures are rarely beyond repair. There are numerous repair methods and materials available to fix almost any problem. When selecting a repair method and material, the repair contractor should consider the objectives of the repair, the cost, the function of the building, and the properties of the repair product. Cost cannot, and should not, be the only consideration when choosing a repair material, but often is the deciding factor when determining if a repair is made.

Due to their many uses and exposure conditions, concrete slabs present unique problems for construction and repair. When these problems are anticipated and properly considered prior to the construction, the slab should provide a long service life without the need for repairs. However, if improper or inadequate construction methods are used the slab will inevitably need to be repaired.

Poor construction practices are the principal cause of problems with concrete slabs. Often, the need for repair



arises before the contractor has even left the jobsite. Overtrowling or overvibration can bring excess fines to the top of the slab and create a weak concrete surface which will easily scale, spall, and dust. Any finishing operation performed while there is still bleed water on the surface will also cause scaling, dusting, and crazing. Inadequate subgrade preparation, insufficient formwork construction, and improper curing will all cause concrete slabs to crack. Failure to properly place and construct joints in the slab will also lead to unwanted cracking.

The problems caused by inadequate or improper construction methods can range from a simple annoyance to a serious structural deficiency. The requirement for repairing these problems will depend on the wishes of the owner, the exposure environment of the slab, and the significance of the problem. Once the requirement for a repair is determined, a long-lasting repair can only be assured through a well thought-out and prepared repair program.

The first step in any repair program must be an assessment of the problem at hand. The *Condition Survey*, accomplished in five steps consisting of: initial preparation, preliminary inspection, detailed inspection, further investigation, and diagnosis, is the preferred method for assessing concrete damage regardless of the age of the concrete. After the condition survey is completed, a repair material and method must be chosen. The repair method





decision is important, as choosing the wrong method can result in a worthless repair. The key factor in choosing a repair material and method should be the objectives of the repair.

Once the method and material are chosen, the surface must be prepared for the actual repair. Preparation is often the single most important aspect of a successful repair. Proper surface preparation includes: sawcutting, removal of loose material, removal of detrimental substances, roughening the surface, and final cleaning of the repair area just prior to commencing the actual repair work.

Finally, repair procedures are critical, but not always well defined. To ensure a good repair, the following principles should always be fulfilled:

1. Use quality repair materials;
2. Thoroughly prepare the surface;
3. Follow proper application procedures.

Although there are many repair materials and procedures available today, it is important to stick to known methods and follow recommended procedures exactly. New, proprietary procedures and materials add another variable to the repair as their results might not yet be proven.

## 5.2 Recommendations

The construction contractor has many concerns, not the least of which are providing a quality product, on time, and within budget. Failure to accomplish any of these three could



result in loss of profits and/or possible legal action. Recommended actions to preclude these possibilities are:

1. DO IT RIGHT THE FIRST TIME! This is the lesson to be learned from having to repair newly constructed concrete slabs. Ignoring the lesson can result in great expense. Enough is known about concrete to prevent premature deterioration. Good concrete is made from cement, sand, aggregate, water, and reinforcement--but so is bad concrete. The difference is in the proper proportioning, mixing, placing, finishing, and curing of the concrete. Distressed concrete is not merely something to be repaired, but a symptom of poor workmanship and lack of supervision in the original construction. [21:29]
2. RECOGNIZE PROBLEMS EARLY. Problems normally worsen with time. Early identification and repair is more cost effective, and may help prevent similar problems on the rest of the job.
3. TACKLE THE CAUSE--NOT THE EFFECT. Successful long-lasting repairs depend on repair strategies that not only correct the problem, but also correct or remove the cause.
4. OPT FOR TOTAL REPAIR, NOT PIECEMEAL. The piecemeal approach may be cheaper up front, but in the long run costs will escalate, especially if the contractor has to return to the jobsite of an already completed project.



5. AVOID OVERGENERALIZING REPAIRS. Every problem situation is different, and each should be assessed on its own conditions.

6. LEAVE THE SOPHISTICATED REPAIRS TO THE EXPERTS.

Enduring repairs often require expensive materials and equipment. Improper use or application of this material and equipment can actually worsen the problem.

7. CONSULT THE MANUFACTURER. When any question arises as to the use or application of any proprietary product, obtain the advise of the producer. Many of these will provide an on-site representative for assistance.

8. USE OTHER RESOURCES. There is an abundance of qualitative and quantitative information available on construction and repair methods, materials and equipment. The American Concrete Institute (ACI), The Portland Cement Association (PCA), and the National Ready Mixed Concrete Association (NRMCA) and others, all publish helpful information, research results, standards and rules for concrete construction.



APPENDIX A  
GUIDE FOR MAKING A CONDITION  
SURVEY OF CONCRETE PAVEMENTS  
(ACI 201.3R-86)





# Guide for Making a Condition Survey of Concrete Pavements

Reported by ACI Committee 201

Paul Klieger, Chairman

Cameron MacInnis, Secretary

Stanley J. Blas, Jr.  
W. Barry Butler  
Ramon Luis Carrasquillo  
Boguslaw Chojnacki  
Kenneth C. Clear  
William A. Cordon  
Bernard Erlin  
Emery Farkas

Eugene D. Hill, Jr.  
Frank J. Hogan  
Joseph F. Lamond  
Kenneth R. Lauer  
Arthur T. Livingood  
Cecil E. Lovewell  
Stella L. Marusin  
Timothy B. Masters

Katharine Mather  
Tarun R. Naik  
Howard Newlon, Jr.  
Robert E. Price  
Thomas J. Reading  
Mauro J. Scali  
Charles F. Scholer  
Jan P. Skalny

Peter Smith  
J. Derle Thorpe  
Claude B. Trusty  
Gary L. Vondran  
Orville R. Werner  
David Whiting  
J. Craig Williams  
Byron I. Zolin

*This guide presents a method for making a condition survey of such concrete pavements as highways, airfields, parking lots, and traffic areas in warehouses. The condition survey consists of (i) an examination of the exposed concrete to identify and define areas of distress and (ii) a determination of the pavement's riding quality. Condition checklists and descriptions of various distress manifestations are included.*

Keywords: airports; concrete durability concrete pavements; cracking (fracturing); highways; joints (junctions); parking facilities; serviceability; surface defects; surveys; warehouses.

## CONTENTS

Chapter 1—Introduction, p. 201.3R-1

Chapter 2—Pavement condition survey, p. 201.3R-1

- 2.1—Riding quality
- 2.2—Distress manifestations

Chapter 3—Checklist, p. 201.3R-2

- 3.1—Description of pavement
- 3.2—Types of distress
- 3.3—Coring and testing

Chapter 4—References, p. 201.3R-22

- 4.1—Specified and/or recommended references
- 4.2—Cited references

### 1—Introduction

This guide presents a method for making a condition survey, including riding quality, of such concrete pavements as highways, airfields, parking lots, and traffic areas in warehouses after a number of years of exposure and use. A condition survey is an examination of

the exposed concrete for the purpose of identifying and defining areas of distress. Riding quality is the degree of riding comfort which the pavement provides to the users. This pavement condition data is used to evaluate the ability of the pavement to continue to provide required service. Several rating schemes have been developed<sup>1,4</sup> for the rating of pavement surface condition. The pavement condition rating requires a comprehensive evaluation of the data. This guide does not include this comprehensive evaluation.

ACI 201.1R, "Guide for Making a Condition Survey of Concrete in Service," has a checklist of items to be considered regarding design, materials of construction, construction practices, and original condition, which supplements the items described in this guide. The information obtained on the items listed in ACI 201.1R, along with information on traffic history and weather records, should be appended to the results of the pavement survey.

This document does not cover the load-carrying capacity of a pavement. Where desired, it can be evaluated by means of static or dynamic methods.<sup>6,8,11</sup>

### 2 — PAVEMENT CONDITION SURVEY

Pavement condition surveys should be made at regular intervals to keep abreast of changing conditions and to plan preventive maintenance and rehabilitation programs with confidence.

The pavement surface to be surveyed is normally divided into sections. In the case of highways, these sec-

ACI Committee Reports, Guides, Standard Practices, and Commentaries are intended for guidance in designing, planning, executing, or inspecting construction and in preparing specifications. Reference to these documents shall not be made in the Project Documents. If items found in these documents are desired to be part of the Project Documents they should be phrased in mandatory language and incorporated into the Project Documents.

Copyright © 1986, American Concrete Institute.

All rights reserved including rights of reproduction and use in any form or by any means, including the making of copies by any photo process, or by any electronic or mechanical device, printed, written, or oral, or recording for sound or visual reproduction or for use in any knowledge or retrieval system or device, unless permission in writing is obtained from the copyright proprietors.



tions are usually 2 to 5 km (1 to 3 miles) long. Sections of highways and airfields are rated for their riding quality and distress manifestations. Generally, for highways, the riding quality is determined only in the driving lanes. The survey of distress manifestations is made at the same time for both lanes of a two-lane highway and for all individual lanes in the same direction of traffic on divided highways. The survey should normally be carried out in fair weather (between late spring and fall in frost regions) when the surface is clear of ice and snow. Other pavements may only be evaluated for distress manifestations.

### 2.1 — Riding Quality

Riding quality of a pavement can be measured quantitatively by mechanical devices such as roughometers and profilometers, or, if the equipment is unavailable or too costly to operate, evaluated by a panel of raters.<sup>4</sup> The latter involves each rater driving over the pavement at the posted speed and rating the pavement on a scale 1:10 based on the riding comfort shown in Table 2.1. The average rating should be used to classify the pavement riding comfort.

The type of vehicle to be used in the evaluation should be standardized by the authority. Raters should not be influenced by the appearance of the pavement surface or the pavement's class (two-lane, four-lane, primary, or secondary highways) when rating riding comfort; only the riding comfort of the pavement should be considered relevant.

There are a variety of mechanical devices for measuring pavement roughness.<sup>6,12,18</sup> Basically, they can be divided into two groups: roughometers and profilometers. Roughometers produce a roughness measurement by integrating the upward vertical movement of a standard suspension system relative to the frame of a vehicle as the vehicle travels over the pavement surface. Profilometers produce a profile of the pavement surface as well as a measurement of roughness. The roughness is expressed in millimeters per kilometer (inches per mile).

The PCA (Portland Cement Association) Road Meter<sup>12,16</sup> and the Mays Road Meter<sup>16,17</sup> are the most commonly used highway pavement roughness measuring devices. There are other devices such as the BPR Roughometer, CHLOE Profilometer, Rolling Straightedge (profilograph), TRRL (British Transport and Road Research Laboratory) Profilometer, Surface Dynamics Profilometer (SDP), and precise leveling method, using a surveying level and rod. Since these methods are more precise than the PCA Road Meter and the Mays Road Meter, they are used to calibrate the two meters. References 6 and 18 contain descriptions of these devices. The SDP, TRRL, or the precise leveling method, using a surveying level and rod, is generally used to obtain profile information in airfield applications. The precise leveling method has application for warehouse floors.

Table 2.1—Riding comfort classification

Riding comfort	Rating
Smooth and pleasant ride	10-8 (excellent)
Comfortable	8-6 (good)
Uncomfortable	6-4 (fair)
Very rough and bumpy	4-2 (poor)
Dangerous at 80 kmh (50 mph)	2-0 (very poor)

### 2.2 — Distress manifestations

Distress manifestations have been categorized and their severity and extent or frequency of occurrence quantified by several organizations.<sup>2,4,19</sup> They are also quantified in this guide.

Pavement distress visibly manifests itself as a surface defect, deformation, joint deficiency, or crack. Section 3.2 categorizes and describes distress manifestations and provides a guide for rating their severity and extent, or frequency of occurrence. Photographs of distress manifestations are provided to facilitate their identification. The rater must possess a basic knowledge of the design, construction, and maintenance of concrete pavement and its behavior under load and weather conditions. He or she must be thoroughly familiar with the various types of distress and the rating scheme before starting the survey in order to maximize objectivity.

## 3 — CHECKLIST

### 3.1 — Description of pavement

Pavement sections under evaluation should be identified by completing the top part of the "Pavement Condition Checklist," Fig. 3.1. The type and width of pavement surface, age of the pavement, and the type and width of the shoulder when present should be shown in addition to the location and length of the section under evaluation.

### 3.2 — Types of distress

The following definitions and photographs are used to identify the type, severity, and extent or frequency of occurrence of distress present. The observations are recorded on the Pavement Conditions Checklist form (Fig. 3.1.).



CONDITION SURVEY OF PAVEMENTS

201.3R-3

HWY. NO. \_\_\_\_\_ CONTRACT NO. \_\_\_\_\_ CONTRACT LENGTH \_\_\_\_\_ km (miles)  
 LOCATION \_\_\_\_\_ DATE OF SURVEY \_\_\_\_\_  
 NUMBER OF EVALUATION SECTIONS \_\_\_\_\_ EVALUATION SECTION NO. \_\_\_\_\_ LENGTH OF EVALUATION SECTION \_\_\_\_\_ km (miles)  
 PAVEMENT: WIDTH \_\_\_\_\_ m (ft.) SHOULDER: SURFACE TYPE \_\_\_\_\_ WIDTH \_\_\_\_\_ m (ft.)

RIDING COMFORT RATING AT 80 km/h (50 mph)		EXCELLENT	GOOD	FAIR	POOR	VERY POOR							
PAVEMENT DISTRESS MANIFESTATIONS		SEVERITY OF PAVEMENT DISTRESS					EXTENT OR FREQUENCY OF PAVEMENT DISTRESS						
		1. (VERY SLIGHT)	2. (SLIGHT)	3. (MODERATE)	4. (SEVERE)	5. (VERY SEVERE)	1. (FEW)	2. (INTERMITTENT)	3. (FREQUENT)	4. (EXTENSIVE)	5. (THROUGHOUT)		
SURFACE DEFECTS	POLISHING												
	AGGREGATE POP-OUTS												
	SCALING OR MORTAR FLAKING OVER COARSE AGGREGATES												
	CRACKING												
	WHEELTRACK WEAR												
	SURFACE DEFORMATION	FAULTING (STEPPING) JOINT CRACK											
SETTLING (SAGGING)													
PUMPING													
JOINT CREEPING													
JOINT DEFICIENCIES	JOINT SEAL LOSS												
	JOINT SEALANT (SEAL) BOND LOSS												
	JOINT SEALANT COHESION FAILURE												
	JOINT SEALANT (SEAL) EXTRUDED												
	JOINT SEALANT IMPREGATED WITH DEBRIS												
	JOINT SEPARATION (LANE OR SHOULDER)												
	LANE SHOULDER DROPOFF OR HEAVE												
	JOINT OR CRACK SPALLING												
	JOINT OR CRACK FAILURE												
	CRACKING	LONGITUDINAL											
MEANDERING													
CORNER													
0													
TRANSVERSE		SINGLE											
		MULTIPLE											
FAULTING													
DIAGONAL													
EDGE													
PUNCHOUT													
MAP CRACKING													
PLASTIC SHRINKAGE CRACKS													
CRACKS AT ENDS OF DOWELS													
PATCHING	FULL WIDTH ASPHALT-PATCH												
	COLD MIX PATCHING												
	PRECAST SLAB												
	FULL WIDTH JOINT REPAIR												
	FULL DEPTH RELIEF JOINT												
	CONCRETE PATCHING												
FULL SLAB REPLACEMENT													
REMARKS:													

Fig. 3.1 — Pavement condition checklist



3.2.1 — Surface defects

3.2.1.1 Polishing — Polished appearance of pavement surface due to glazing of coarse aggregate particles.



Fig. 3.2.1.1 — Polished pavement

Table 3.2.1.1—Severity and extent of polishing

<u>Severity</u>	<u>Appearance</u>
1. (very slight)	Barely noticeable
2. (slight)	Noticeable
3. (moderate)	Distinctive dull finish
4. (severe)	Glossy mirror-finished surface
5. (very severe)	Highly polished

<u>Extent</u>	<u>Percent of lane area affected</u>
1. (few)	< 10
2. (intermittent)	10 - 25
3. (frequent)	26 - 50
4. (extensive)	51 - 80
5. (throughout)	81 - 100

3.2.1.2 Aggregate pop-outs— The breaking away of small portions of a concrete surface due to internal pressure, which leaves a shallow, typically conical depression.



Fig. 3.2.1.2 — Aggregate pop-outs

Table 3.2.1.2—Severity and extent of aggregate pop-outs

<u>Severity</u>	<u>Appearance</u>
1. (very slight)	Barely noticeable
2. (slight)	Noticeable
3. (moderate)	Pock-marked, pock marks fairly frequent
4. (severe)	Pock-marked, pock marks closely spaced
5. (very severe)	Raveled

<u>Extent</u>	<u>Percent of lane area affected</u>
1. (few)	< 10
2. (intermittent)	10 - 25
3. (frequent)	26 - 50
4. (extensive)	51 - 80
5. (throughout)	81 - 100





**3.2.1.3 Spalls**— Fragments, usually in the shape of a flake, detached from a larger mass by a blow, by the action of weather, by pressure, or by expansion within the larger mass.



Fig. 3.2.1.3 — Severe spall

Table 3.2.1.3—Severity and extent of spalls

<u>Severity</u>	<u>Appearance</u>
1. (very slight)	Barely noticeable
2. (slight)	Clearly noticeable
3. (moderate)	Hole larger than pop-out of coarse aggregate
4. (severe)	150 mm (6 in.) in diameter and at least 150 mm (6 in.) deep
5. (very severe)	Large hole interfering with rideability

<u>Extent</u>	<u>Percent of lane area affected</u>
1. (few)	< 10
2. (intermittent)	10 - 25
3. (frequent)	26 - 50
4. (extensive)	51 - 80
5. (throughout)	81 - 100

**3.2.1.4 Scaling or mortar flaking over coarse aggregate** — Local flaking or peeling away of the near-surface portion of hardened concrete or mortar [Fig. 3.2.1.4(a)] or a thin layer of mortar flakes off the surface of coarse aggregate [Fig. 3.2.1.4(b)].

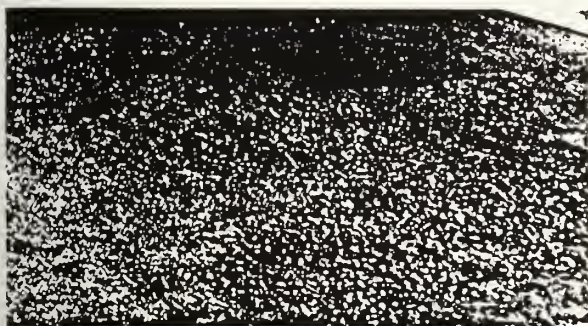

Fig. 3.2.1.4(a) — Scaling

Table 3.2.1.4—Severity and extent of scaling/mortar flaking over coarse aggregate

<u>Severity</u>	<u>Appearance</u>
1. (very slight)	Barely noticeable
2. (slight)	Noticeable
3. (moderate)	Open texture or 10 to 25 cavities over coarse aggregate per m <sup>2</sup>
4. (severe)	Disintegration in closely spaced shallow patches or closely spaced (26 to 50) cavities over coarse aggregate per m <sup>2</sup>
5. (very severe)	Disintegration

<u>Extent</u>	<u>Percent of lane area affected</u>
1. (few)	< 10
2. (intermittent)	10 - 25
3. (frequent)	26 - 50
4. (extensive)	51 - 80
5. (throughout)	81 - 100



Fig. 3.2.1.4(b) — Mortar flaking over coarse aggregate



3.2.1.5 *Crazing* — Fine, hairline cracks apparently extending only through the surface layer and tending to intersect at an angle of approximately 120 deg forming a chicken-wire pattern.

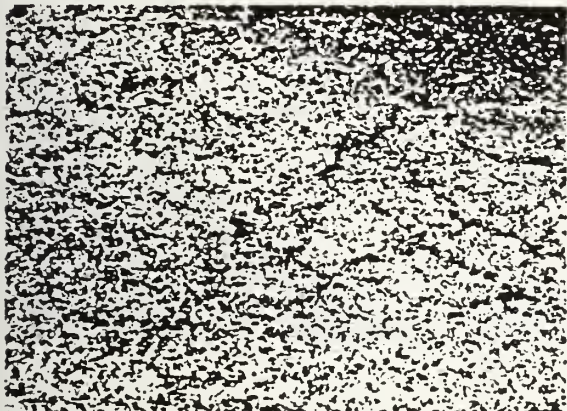

Fig. 3.2.1.5 — Crazing

3.2.1.6 *Wheel track wear* — Trough-like depression in the wheel path.



Fig. 3.2.1.6 — Wheel track wear

Table 3.2.1.5—Severity and extent of crazing

<u>Severity</u>	<u>Appearance</u>
1. (very slight)	Barely noticeable in scattered areas when drying after rain
2. (slight)	Barely noticeable over the whole surface when drying after rain
3. (moderate)	Noticeable over the whole area at all times
4. (severe)	Well pronounced in scattered areas
5. (very severe)	Well pronounced over the whole area

<u>Extent</u>	<u>Percent of lane area affected</u>
1. (few)	< 10
2. (intermittent)	10 - 25
3. (frequent)	26 - 50
4. (extensive)	51 - 80
5. (throughout)	81 - 100

Table 3.2.1.6—Severity and extent of wheel track wear

<u>Severity</u>	<u>Depth of depression, mm</u>
1. (very slight)	0 - 5
2. (slight)	6 - 10
3. (moderate)	11 - 15
4. (severe)	16 - 20
5. (very severe)	> 20

<u>Extent</u>	<u>Percent of lane length affected</u>
1. (few)	< 10
2. (intermittent)	10 - 25
3. (frequent)	26 - 50
4. (extensive)	51 - 80
5. (throughout)	81 - 100



3.2.2 —Surface deformations

3.2.2.1 *Faulting (stepping)* — Differential vertical displacement of abutting slabs at joints or cracks creating a “step” deformation in the pavement surface.



Fig. 3.2.2.1 — Faulting (stepping)

Table 3.2.2.1—Severity and frequency of faulting (stepping)

Severity	Height of fault
1. (very slight)	Barely noticeable
2. (slight)	Noticeable
3. (moderate)	3 - 6 mm (1/8-1/4 in.)
4. (severe)	7 - 15 mm (1/4-3/8 in.)
5. (very severe)	> 15 mm (3/8 in.)

Frequency	Number of faults per km
1. (few)	< 5
2. (intermittent)	5 - 10
3. (frequent)	11 - 20
4. (extensive)	21 - 50
5. (throughout)	> 50

3.2.2.2 *Settling (sagging)* — The lowering in elevation of sections of pavement due to the displacement of the support.



Fig. 3.2.2.2 — Settling (sagging)

Table 3.2.2.2.—Severity and frequency of settling (sagging)

Severity	Rideability
1. (very slight)	Noticeable change (swaying motion)
2. (slight)	Good control of car still present for driver of vehicle
3. (moderate)	Fair control of car when driving over pavement
4. (severe)	Poor control when driving over pavement with driver always having to anticipate settling ahead
5. (very severe)	Continuous settling making it a dangerous situation if driving car at a speed greater than 60 kmh (40 mph)

Frequency	Number of faults per km
1. (few)	1
2. (intermittent)	2
3. (frequent)	3
4. (extensive)	4 - 5
5. (throughout)	> 5



3.2.2.3 *Pumping* — The ejection of water, or water and solid materials such as clay or silt, along transverse or longitudinal joints and cracks and along pavement edges.



Fig. 3.2.2.3(a) — *Pumping (slight)*



Fig. 3.2.2.3(b) — *Pumping (very severe)*

Table 3.2.2.3—Severity and extent of pumping

Severity	Appearance
1. (very slight)	Small amount of water forced out of a joint or cracks when trucks pass over the joint or crack. No fines observed
2. (slight)	Substantial amount of water forced out when trucks pass over the joint or crack. No fines observed.
3. (moderate)	A small amount of pumped material can be observed near some of the joints or cracks on the surface of the traffic lane or shoulder
4. (severe)	A significant amount of pumped materials exists on the pavement surface along the joints or cracks
5. (very severe)	A large amount of pumped material exists on the pavement surface along the joints or cracks

Extent	Number of joints or cracks affected per km*
1. (few)	< 5
2. (intermittent)	5 - 10
3. (frequent)	11 - 15
4. (extensive)	16 - 25
5. (throughout)	> 25

\*If longitudinal joint, number of affected sections per Km.





**3.2.3 — Joint deficiencies**

**3.2.3.1 Joint creeping** — One lane's transverse joint moves ahead (or behind) the one in the adjacent lane from its original alignment straight across both lanes.

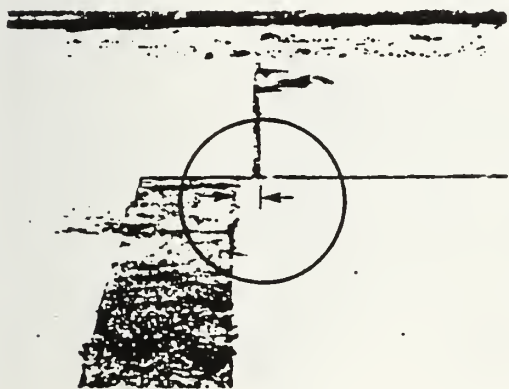

Fig. 3.2.3.1 — Joint creeping

**Table 3.2.3.1—Severity and frequency of joint creeping**

<u>Severity</u>	<u>Appearance</u>
1. (very slight)	Joint barely out of line
2. (slight)	Noticeably out of line
3. (moderate)	12 - 25 mm (½-¾ in.) out of line
4. (severe)	26 - 50 mm (1 - 2 in.) out of line
5. (very severe)	> 50 mm (> 2 in.) out of line

<u>Frequency</u>	<u>Percent of joints showing distress</u>
1. (few)	< 10
2. (intermittent)	10 - 25
3. (frequent)	26 - 50
4. (extensive)	51 - 80
5. (throughout)	81 - 100

**3.2.3.2 Joint seal loss** — Transverse or longitudinal joint seal being squeezed or pulled out of the joint.



Fig. 3.2.3.2 — Joint seal loss

**Table 3.2.3.2—Severity and frequency of joint seal loss**

<u>Severity</u>	<u>Appearance</u>
1. (very slight)	Barely pop-out or breaking
2. (slight)	Seal broken and begins to pull out [up to 300 mm (1 ft)]
3. (moderate)	Seal broken and pulled out up to 50 percent of its length
4. (severe)	Seal broken and pulled out up to 80 percent of its length
5. (very severe)	Seal completely broke and pulled out more than 80 percent of its length

<u>Frequency</u>	<u>Percent of joints showing distress</u>
1. (few)	< 10
2. (intermittent)	10 - 25
3. (frequent)	26 - 50
4. (extensive)	51 - 80
5. (throughout)	81 - 100



3.2.3.3 *Joint sealant (seal) bond loss* — A bond failure (or a gap) between joint sealant (seal) and the face of the joint groove.

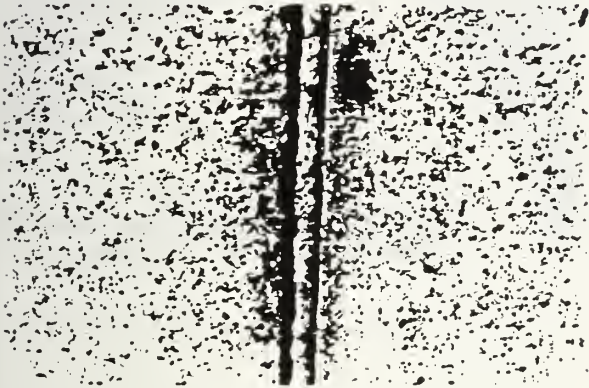

Fig. 3.2.3.3 — *Joint sealant bond loss*

3.2.3.4 *Joint sealant cohesion failure* — A rupture (crack) within the sealant itself, parallel to the joint.

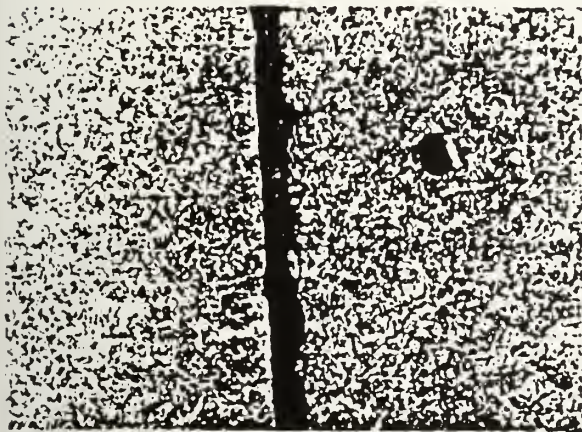

Fig. 3.2.3.4 — *Joint sealant cohesion failure*

Table 3.2.3.3—Severity and extent of joint sealant (seal) bond loss

<u>Severity</u>	<u>Bond failure percent of joint length</u>
1. (very slight)	< 10
2. (slight)	10 - 25
3. (moderate)	26 - 50
4. (severe)	51 - 75
5. (very severe)	76 - 100
<u>Extent</u>	<u>Percent of joints affected</u>
1. (few)	< 10
2. (intermittent)	10 - 25
3. (frequent)	26 - 50
4. (extensive)	51 - 80
5. (throughout)	81 - 100

Table 3.2.3.4—Severity and extent of joint sealant cohesion failure

<u>Severity</u>	<u>Cohesion failure, percent of joint length</u>
1. (very slight)	< 10
2. (slight)	10 - 25
3. (moderate)	26 - 50
4. (severe)	51 - 75
5. (very severe)	76 - 100
<u>Extent</u>	<u>Percent of joints affected</u>
1. (few)	< 10
2. (intermittent)	10 - 25
3. (frequent)	26 - 50
4. (extensive)	51 - 80
5. (throughout)	81 - 100



3.2.3.5 Joint sealant (seal) extruded — Joint sealant (seal) extruded and flattened by traffic (protruding above joint edges).



Fig. 3.2.3.5 — Joint sealant extruded

Table 3.2.3.5—Severity and frequency of joint sealant (seal) extrusion

<u>Severity</u>		<u>Protrusion above joint edges</u> <u>(compression seals)</u>
1. (very slight)		Barely noticeable < 1 mm (< 1/16 in.)
2. (slight)		Noticeable 1 - 3 (1/16 - 1/8 in.)
3. (moderate)		3 - 6 mm (1/8 - 1/4 in.)
4. (severe)		6 - 12 mm (1/4 - 1/2 in.)
5. (very severe)		> 12 mm (> 1/2 in.)

<u>Severity</u>		<u>Area covered by flattened sealant</u> <u>(field molded sealants)</u>
1. (very slight)		Barely noticeable
2. (slight)		Noticeable
3. (moderate)		0.05 - 0.10 m <sup>2</sup> (0.5 - 1.0 ft <sup>2</sup> )
4. (severe)		0.10 - 0.25 m <sup>2</sup> (1.0 - 2.5 ft <sup>2</sup> )
5. (very severe)		> 0.25 m <sup>2</sup> (> 2.5 ft <sup>2</sup> )

<u>Frequency</u>	<u>Number of distressed joints per km</u>
1. (few)	< 5
2. (intermittent)	5 - 10
3. (frequent)	11 - 15
4. (extensive)	16 - 25
5. (throughout)	> 25

3.2.3.6 Joint sealant impregnated with debris — Incompressible solids such as aggregate particles embedded in the field-molded sealant.

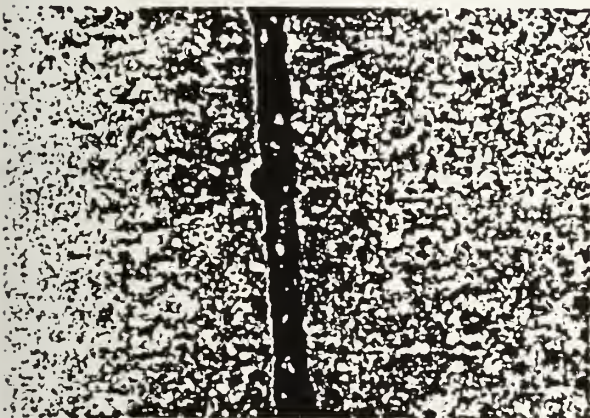

Fig. 3.2.3.6 — Joint sealant impregnated with debris

Table 3.2.3.6—Severity and extent of joint sealant impregnated with debris

<u>Severity</u>	<u>Appearance</u>
1. (very slight)	Several particles no larger than one-quarter the width of the joint embedded in the sealant
2. (slight)	Several particles not larger than one-half the width of the joint embedded in the sealant
3. (moderate)	Several particles not larger than three-quarters the width of the joint embedded in the sealant
4. (severe)	Many particles not larger than three-quarters the width of the joint embedded in the sealant
5. (very severe)	Many particles, some equal in size to the width of the joint, embedded in the sealant

<u>Extent</u>	<u>Percent of joints affected</u>
1. (few)	< 10
2. (intermittent)	10 - 25
3. (frequent)	26 - 50
4. (severe)	51 - 80
5. (throughout)	81 - 100



3.2.3.7 *Joint separation (lane or shoulder)* — The widening of the longitudinal joint between two adjacent lanes or the widening of the joint between the lane and the shoulder.



Fig. 3.2.3.7 — Joint separation

Table 3.2.3.7—Severity and extent of joint separation

Severity	Widening
1. (very slight)	< 2 mm (< 1/16 in.)
2. (slight)	2 - 6 mm (1/8 - 1/4 in.)
3. (moderate)	6 - 12 mm (1/4 - 1/2 in.)
4. (severe)	12 - 20 mm (1/2 - 3/4 in.)
5. (very severe)	> 20 mm (> 3/4 in.)
Extent	Percent of joint length affected
1. (few)	< 10
2. (intermittent)	10 - 25
3. (frequent)	26 - 50
4. (extensive)	51 - 80
5. (throughout)	81 - 100

3.2.3.8 *Lane/shoulder dropoff or heave* — A difference in elevation between the lane and shoulder or between two adjacent lanes along the longitudinal joint.



Fig. 3.2.3.8 — Lane/shoulder dropoff

Table 3.2.3.8—Severity and Extent of Lane/Shoulder Dropoff

Severity	Height of fault
1. (very slight)	Barely noticeable
2. (slight)	3 - 6 mm (1/8 - 1/4 in.)
3. (moderate)	6 - 15 mm (1/4 - 3/8 in.)
4. (severe)	15 - 25 mm (3/8 - 1 in.)
5. (very severe)	> 25 mm (> 1 in.)
Extent	Percent of joint length affected
1. (few)	< 10
2. (intermittent)	10 - 25
3. (frequent)	26 - 50
4. (extensive)	51 - 80
5. (throughout)	81 - 100





**3.2.3.9 Joint or crack spalling** — The cracking, breaking, or chipping of the slab edges within 0.6 m (2 ft) of the transverse or longitudinal joints, or transverse or longitudinal cracks.



Fig. 3.2.3.9 — Joint spalling

**Table 3.2.3.9—Severity and frequency of joint/crack spalling**

<u>Severity</u>	<u>Appearance</u>
1. (very slight)	Less than 0.6 m (2 ft) long and extending not more than 0.1 m (4 in.) from the joint or crack, no loose or missing pieces
2. (slight)	As above but some pieces are loose or missing
3. (moderate)	More than 0.6 m (2 ft) long, broken into pieces, fray extends more than 0.1 m (4 in.) from the edge of joint or crack, some small pieces missing but does not present a safety hazard
4. (severe)	As above but large pieces are missing, presenting a safety hazard
5. (very severe)	As above but on both sides of joint or crack

<u>Frequency</u>	<u>Number of joints per km</u>
1. (few)	< 10
2. (intermittent)	10 - 25
3. (frequent)	26 - 50
4. (extensive)	51 - 80
5. (throughout)	> 80

**3.2.3.10 Joint/crack failure (blowup, crushing, or compression failure)** — Severe breakdown of slab adjacent to transverse joint or crack such that patching is required to maintain or restore rideability.



Fig. 3.2.3.10 — Joint failure

**Table 3.2.3.10—Severity and frequency of joint/crack failure**

<u>Severity</u>	<u>Appearance</u>
All are severe or very severe because it presents a very distressing visual effect, very rough ride, and safety hazard	

<u>Frequency</u>	<u>Number of distressed joints per km</u>
1. (few)	1
2. (intermittent)	2 - 3
3. (frequent)	4 - 7
4. (extensive)	8 - 10
5. (throughout)	> 10



### 3.2.4 — Cracks

Cracking is defined as a separation into two or more parts. Cracks can be classified by their orientation in relation to the longitudinal axis of the pavement.

**3.2.4.1 Longitudinal cracks** — Cracks which follow a course approximately parallel to the centerline of the pavement and are generally quite straight.



Fig. 3.2.4.1 — Longitudinal cracks

Table 3.2.4.1—Severity and extent of longitudinal cracks

Severity	Appearance
1. (very slight)	< 1 mm ( $\frac{1}{32}$ in.) in width
2. (slight)	1 - 10 mm ( $\frac{1}{8}$ - $\frac{3}{8}$ in.) in width
3. (moderate)	10 - 20 mm ( $\frac{3}{8}$ - $\frac{1}{2}$ in.) in width
4. (severe)	20 - 25 mm ( $\frac{3}{4}$ - 1 in.) in width
5. (very severe)	> 25 mm (1 in.) in width with spalling and/or faulting
Extent	Percent of lane length affected
1. (few)	< 10
2. (intermittent)	10 - 25
3. (frequent)	26 - 50
4. (extensive)	51 - 80
5. (throughout)	81 - 100

**3.2.4.2 Meandering cracks** — Cracks which wander like a serpent across the traffic lane and generally occur at a transverse joint.



Fig. 3.2.4.2 — Meandering crack

Table 3.2.4.2—Severity and extent of meandering cracks

Severity	Appearance
1. (very slight)	< 1 mm ( $\frac{1}{32}$ in.) in width
2. (slight)	1 - 10 mm ( $\frac{1}{8}$ - $\frac{3}{8}$ in.) in width
3. (moderate)	10 - 20 mm ( $\frac{3}{8}$ - $\frac{1}{2}$ in.) in width
4. (severe)	20 - 25 mm ( $\frac{3}{4}$ - 1 in.) in width
5. (very severe)	> 25 mm (1 in.) in width with spalling and/or faulting
Extent	Percent of lane length affected
1. (few)	< 10
2. (intermittent)	10 - 25
3. (frequent)	26 - 50
4. (extensive)	51 - 80
5. (throughout)	81 - 100



### 3.2.4 — Cracks

Cracking is defined as a separation into two or more parts. Cracks can be classified by their orientation in relation to the longitudinal axis of the pavement.

**3.2.4.1 Longitudinal cracks** — Cracks which follow a course approximately parallel to the centerline of the pavement and are generally quite straight.



Fig. 3.2.4.1 — Longitudinal cracks

Table 3.2.4.1—Severity and extent of longitudinal cracks

Severity	Appearance
1. (very slight)	< 1 mm ( $\frac{1}{32}$ in.) in width
2. (slight)	1 - 10 mm ( $\frac{1}{16}$ - $\frac{3}{16}$ in.) in width
3. (moderate)	10 - 20 mm ( $\frac{3}{8}$ - $\frac{1}{2}$ in.) in width
4. (severe)	20 - 25 mm ( $\frac{3}{4}$ - 1 in.) in width
5. (very severe)	> 25 mm (1 in.) in width with spalling and/or faulting

Extent	Percent of lane length affected
1. (few)	< 10
2. (intermittent)	10 - 25
3. (frequent)	26 - 50
4. (extensive)	51 - 80
5. (throughout)	81 - 100

**3.2.4.2 Meandering cracks** — Cracks which wander like a serpent across the traffic lane and generally occur at a transverse joint.



Fig. 3.2.4.2 — Meandering crack

Table 3.2.4.2—Severity and extent of meandering cracks

Severity	Appearance
1. (very slight)	< 1 mm ( $\frac{1}{32}$ in.) in width
2. (slight)	1 - 10 mm ( $\frac{1}{16}$ - $\frac{3}{16}$ in.) in width
3. (moderate)	10 - 20 mm ( $\frac{3}{8}$ - $\frac{1}{2}$ in.) in width
4. (severe)	20 - 25 mm ( $\frac{3}{4}$ - 1 in.) in width
5. (very severe)	> 25 mm (1 in.) in width with spalling and/or faulting

Extent	Percent of lane length affected
1. (few)	< 10
2. (intermittent)	10 - 25
3. (frequent)	26 - 50
4. (extensive)	51 - 80
5. (throughout)	81 - 100



**3.2.4.3 Corner cracks** — Diagonal cracks forming a triangle with a longitudinal edge or joint and a transverse joint or crack. The size of the triangle so formed is generally about 0.3 m (1 ft) and with few exceptions no larger than 0.6 m (2 ft).



Fig. 3.2.4.3 — Corner crack

**3.2.4.4 D-cracking** — The progressive formation of a series of closely spaced fine crescent-shaped cracks in the concrete surface, usually paralleling edges, joints, and cracks and usually curving across slab corners.



Fig. 3.2.4.4 — D-cracking

Table 3.2.4.3—Severity and frequency of corner cracks

Severity	Appearance
1. (very slight)	< 1 mm (1/16 in.) in width
2. (slight)	1 - 10 mm (1/8 - 3/8 in.) in width
3. (moderate)	10 - 20 mm (3/8 - 3/4 in.) in width
4. (severe)	20 - 25 mm (3/4 - 1 in.) in width
5. (very severe)	> 25 mm (1 in.) with spalling and/or faulting

Frequency	Percent of Corners Affected
1. (few)	< 10
2. (intermittent)	10 - 25
3. (frequent)	26 - 50
4. (extensive)	51-80
5. (throughout)	81 - 100

Table 3.2.4.4—Severity and extent of D-cracking

Severity	Width of D-cracked area
1. (very slight)	Zero width, but corner cracked for 150 mm (6 in.) maximum
2. (slight)	Less than 250 mm (10 in.) width at the center of the lane; pattern fans out at the edge and longitudinal joints; no spalling
3. (moderate)	As above but up to moderate severity spalling has developed
4. (severe)	More than 250 mm (12 in.) width at the center of the lane with up to severe spalling
5. (very severe)	As above, but the spalling is very severe

Extent	Percent of lane area affected
1. (few)	< 10
2. (intermittent)	10 - 25
3. (frequent)	26 - 50
4. (extensive)	51 - 80
5. (throughout)	81 - 100





3.2.4.5 *Transverse cracks* — Cracks which follow a course approximately at right angles to the pavement centerline.

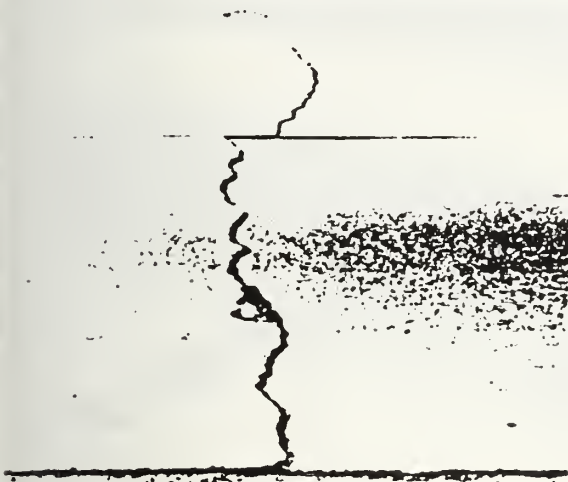

Fig. 3.2.4.5(a) — *Transverse crack, single*

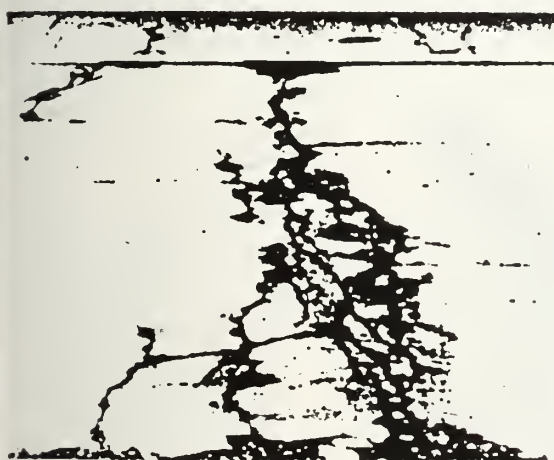

Fig. 3.2.4.5(b) — *Transverse crack, multiple*

Table 3.2.4.5—Severity and frequency of transverse cracks

<u>Severity</u>	<u>Appearance</u>
1. (very slight)	< 1 mm ( $\frac{1}{32}$ in.) in width with no faulting or spalling
2. (slight)	1 - 10 mm ( $\frac{1}{16}$ - $\frac{3}{16}$ in.) in width with very slight faulting or spalling
3. (moderate)	10 - 20 mm ( $\frac{3}{8}$ - $\frac{1}{2}$ in.) in width with slight spalling or faulting (single or multiple cracks)
4. (severe)	20 - 25 mm ( $\frac{3}{4}$ - 1 in.) in width with spalling, faulting (single or multiple cracks)
5. (very severe)	Over 25 mm (1 in.) in width with spalling, faulting, and debris trapped in between (single or multiple cracks)

<u>Frequency</u>	<u>Number of cracks per km</u>
1. (few)	< 10
2. (intermittent)	10 - 25
3. (frequent)	26 - 50
4. (extensive)	51 - 80
5. (throughout)	> 80



3.2.4.6 *Diagonal cracks* — Crack which follows a course approximately diagonal to the centerline.



Fig. 3.2.4.6 — Diagonal crack

3.2.4.7 *Edge cracks* — Arc cracks extending from transverse joint or crack to the pavement edge generally 0.50 to 0.75 m (2 to 3 ft) inward from the pavement edge and covering an area of 4 to 5 m (15 to 20 ft) from end to end.



Fig. 3.2.4.7 — Edge crack

Table 3.2.4.6—Severity and frequency of diagonal cracks

Severity	Appearance
1. (very slight)	< 1 mm ( $\frac{1}{32}$ in.) in width
2. (slight)	1 - 10 mm ( $\frac{1}{16}$ - $\frac{3}{8}$ in.) in width
3. (moderate)	10 - 20 mm ( $\frac{3}{8}$ - $\frac{3}{4}$ in.) in width
4. (severe)	20 - 25 mm ( $\frac{3}{4}$ - 1 in.) in width
5. (very severe)	> 25 mm (1 in.) in width with spalling and/or faulting

Frequency	Number of cracks per km
1. (few)	< 10
2. (intermittent)	10 - 25
3. (frequent)	26 - 50
4. (extensive)	51 - 80
5. (throughout)	81 - 100

Table 3.2.4.7—Severity and frequency of edge cracks

Severity	Appearance
1. (very slight)	< 1 mm ( $\frac{1}{32}$ in.) in width
2. (slight)	1 - 10 mm ( $\frac{1}{16}$ - $\frac{3}{8}$ in.) in width
3. (moderate)	10 - 20 mm ( $\frac{3}{8}$ - $\frac{3}{4}$ in.) in width
4. (severe)	20 - 25 mm ( $\frac{3}{4}$ - 1 in.) in width
5. (very severe)	> 25 mm (1 in.) in width with spalling and/or faulting

Extent	Percent of lane length affected
1. (few)	< 10
2. (intermittent)	10 - 25
3. (frequent)	26 - 50
4. (extensive)	51 - 80
5. (throughout)	81 - 100



3.2.4.8 *Punchout* — A localized area of the slab that is broken into pieces. It can take many different shapes and forms but it is usually defined by a crack and a joint, or two closely spaced cracks (usually 1.5 m apart).

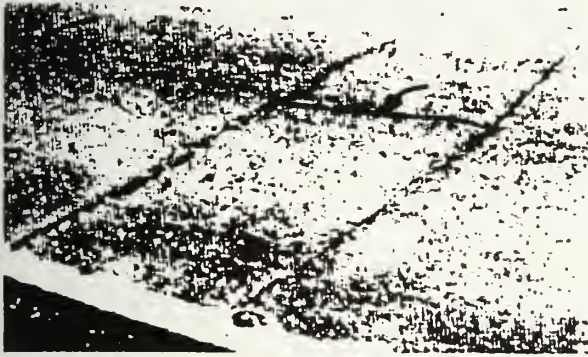

Fig. 3.2.4.8(a) — *Punchout, Severity 2*



Fig. 3.2.4.8(b) — *Punchout, Severity 5*

Table 3.2.4.8—Severity and extent of punchout

<u>Severity</u>	<u>Appearance</u>
1. (very slight)	Maximum three pieces or majority of cracks up to 1 mm ( $\frac{1}{32}$ in.) in width
2. (slight)	Maximum four pieces or majority of cracks up to 20 mm ( $\frac{3}{4}$ in.) in width with slight spalling
3. (moderate)	Maximum five pieces or majority of cracks up to 25 mm (1 in.) in width with spalling
4. (severe)	Over five pieces or majority of cracks up to 25 mm (1 in.) in width with spalling
5. (very severe)	Over five pieces or majority of cracks over 25 mm (1 in.) in width with spalling

<u>Extent</u>	<u>Percent of lane area affected</u>
1. (few)	< 10
2. (intermittent)	10 - 25
3. (frequent)	26 - 50
4. (extensive)	51 - 80
5. (throughout)	81 - 100



3.2.4.9 *Map cracking* — Interconnected cracks forming networks of any size and usually similar geometrically to those seen on dried mud flats.

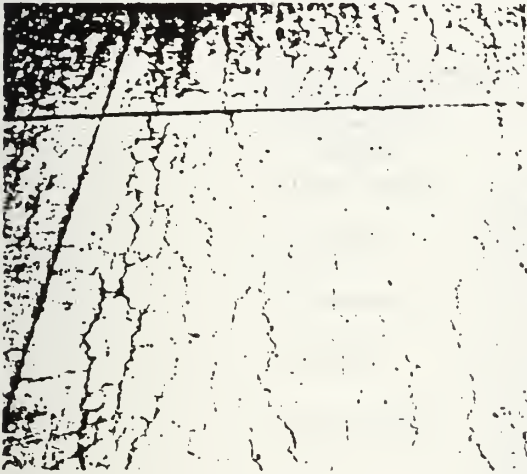

Fig. 3.2.4.9 — Map cracking

Table 3.2.4.9—Severity and extent of map cracking

<u>Severity</u>	<u>Appearance</u>
1. (very slight)	Barely noticeable
2. (slight)	Clearly visible with no raveling
3. (moderate)	Clearly visible with some raveling evident
4. (severe)	Cracks raveled over substantial amount of the affected area
5. (very severe)	Cracks severely raveled or spalled
<u>Extent</u>	<u>Percent of lane area affected</u>
1. (few)	< 10
2. (intermittent)	10 - 25
3. (frequent)	26 - 50
4. (extensive)	51 - 80
5. (throughout)	81 - 100

3.2.4.10 *Plastic shrinkage cracks* — Cracks that occur in the surface of fresh concrete soon after it is placed and while it is still plastic. They are usually parallel to each other on the order of 300 to 900 mm (1 to 3 ft) apart. They do not usually extend across the entire slab and do not usually extend through the entire depth of the slab.



Fig. 3.2.4.10 — Plastic shrinkage cracks

Table 3.2.4.10—Severity and extent of plastic shrinkage cracks

<u>Severity</u>	<u>Appearance</u>
1. (very slight)	Barely noticeable
2. (slight)	Clearly visible with no raveling
3. (moderate)	Clearly visible with some raveling evident
4. (severe)	Cracks raveled
5. (very severe)	Cracks severely raveled or spalled
<u>Extent</u>	<u>Percent of lane area affected</u>
1. (few)	< 10
2. (intermittent)	10 - 25
3. (frequent)	26 - 50
4. (extensive)	51 - 80
5. (throughout)	81 - 100





3.2.4.11 *Cracks at ends of dowels* — A transverse crack a short distance from a transverse joint, usually at the end of joint load transfer dowels.

**Table 3.2.4.11—Severity and extent of cracks at ends of dowels**

<u>Severity</u>	<u>Appearance</u>
1. (very slight)	< 1 mm ( $\frac{1}{32}$ in.) in width with no faulting or spalling
2. (slight)	1 - 10 mm ( $\frac{1}{16}$ - $\frac{3}{16}$ in.) in width with very slight spalling or faulting
3. (moderate)	10 - 20 mm ( $\frac{3}{8}$ - $\frac{1}{2}$ in.) in width with slight spalling or faulting
4. (severe)	20 - 25 mm ( $\frac{3}{4}$ - 1 in.) in width with spalling and faulting
5. (very severe)	Over 25 mm (1 in.) in width with spalling, faulting, and debris trapped in between

<u>Extent</u>	<u>Number of distressed joints per km</u>
1. (few)	< 1
2. (intermittent)	2 - 3
3. (frequent)	4 - 7
4. (extensive)	8 - 10
5. (throughout)	> 10

### 3.2.5 — Patches

The presence of remedial measures taken to improve the rideability of the pavement should also be identified and recorded in Fig. 3.1. The measures are: hot mix patching, transverse joint repair, pressure relief joint, precast concrete slab, cold mix patching.



Fig. 3.2.5.1(a) — Precast concrete slab



Fig. 3.2.5.1(b) — Hot mix patch





Fig. 3.2.5.1(c) — Cold mix patch

Table 3.2.5.1—Extent of precast slab and hot or cold mix patching

Extent	Percent of lane area affected
1. (few)	< 10
2. (intermittent)	10 - 25
3. (frequent)	26 - 50
4. (extensive)	51 - 80
5. (throughout)	81 - 100

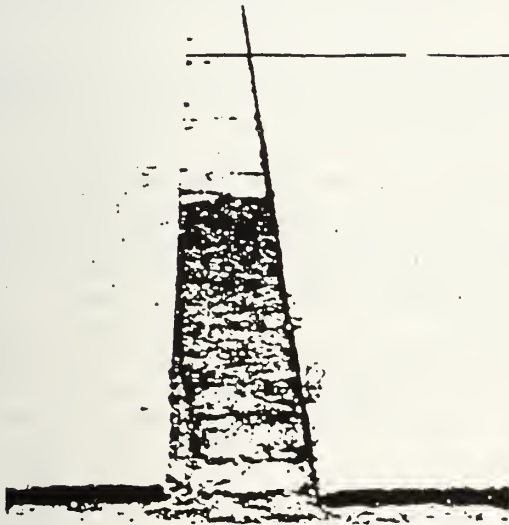

Fig. 3.2.5.2(a) — Repaired transverse joint

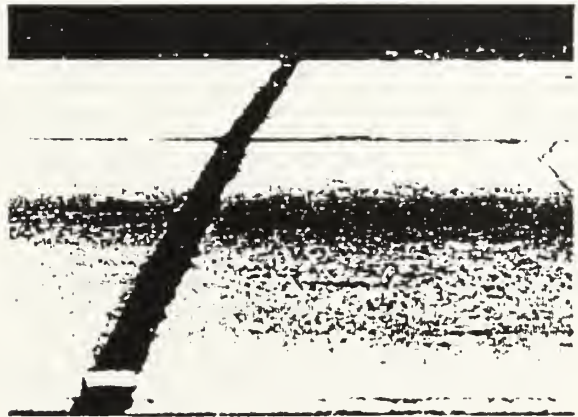

Fig. 3.2.5.2(b) — Pressure relief joint

Table 3.2.5.2—Frequency of pressure relief joints and repaired transverse joints

Extent	Number of affected joints per km
1. (few)	< 5
2. (intermittent)	5 - 10
3. (frequent)	11 - 15
4. (extensive)	16 - 25
5. (throughout)	> 25

**3.3. — Coring and testing**

A program of coring is recommended to obtain information on the actual structure of the pavement and quality of the materials. This information will be useful in determining the load-bearing capacity and durability of the pavement, and will also help to determine the cause(s) of some of the distress manifestations. It is suggested that at least one full-depth core for each 1000 m<sup>2</sup> (10,000 ft<sup>2</sup>) or at least three full-depth cores, whichever is greater, be obtained. All the cores should be tested for depth of pavement and base (ASTM C 174) and type of base (lean concrete, bituminous, etc.).

Some of them should then be tested for compressive strength (ASTM C 42), and some for air void system (ASTM C 457), quality of paste and aggregate (petrographic examination, ASTM C 856). As some of the concrete distress observed may be caused by the condition of the subbase and/or subgrade, their existing condition should also be investigated and noted on the "Remarks" section of the checklist.

The sides of the core holes must be cleaned and any free water removed before filling the holes by tamping a stiff mixture of a durable repair material in layers until the hole is filled level with the pavement surface.



## 4 — REFERENCES

## 4.1 — Specified and/or recommended references

The documents of the various standards-producing organizations referred to in this document are listed below with their serial designation, including year of adoption or revision. The documents listed were the latest effort at the time this document was written. Since some of these documents are revised frequently, generally in minor detail only, the user of this document should check directly with the sponsoring group if it is desired to refer to the latest revision.

*American Concrete Institute*

201.1R-68 Guide for Making a Condition Survey of Concrete in Service (Revised 1984)

*ASTM*

- C 42-84A Standard Method of Obtaining and Testing Drilled Cores and Sawed Beams of Concrete
- C 174-82 Standard Method of Measuring Length of Drilled Concrete Cores
- C 457-82A Standard Practice for Microscopical Determination of Air-Void Content and Parameters of Air-Void System in Hardened Concrete
- C 856-83 Standard Practice for Petrographic Examination of Hardened Concrete

These publications may be obtained from:

American Concrete Institute  
P.O. Box 19150  
Detroit, Mich. 48219

ASTM  
1916 Race St.  
Philadelphia, Pa., 19103

## 4.2 — CITED REFERENCES

1. Shahin, M. Y., "Components of a Pavement Maintenance Management System," U.S. Army Construction Engineering Research Laboratory, Champaign, July 1980, 28 pp.
2. Shahin, M. Y., and Kohn, S. D., "Development of a Pavement Condition Rating Procedure for Roads, Streets, and Parking Lots, Vol. 11: Distress Identification Manual," *Technical Report* No. M-268, U.S. Army Construction Engineering Research Laboratory, Champaign, July 1979, pp. 64-115.
3. Shahin, M. Y.; Darter, M. I.; and Kohn, S. D., "Development of a Pavement Maintenance Management System, Vol. 1: Airfield Pavement Condition Rating," U.S. Army Construction Engineering Research Laboratory, Champaign, Nov. 1976, 220 pp.
4. Chong, G. J.; Phang, W. A.; and Wong, G. A., "Manual for Condition Rating of Rigid Pavements, Distress Manifestations," Ontario Ministry of Transportation and Communications, Downsview, Aug. 1977, 66 pp.

5. Carey, W. N., Jr., and Irick, P. E., "The Pavement Serviceability-Performance Concept," *Bulletin* No. 250, Highway Research Board, Washington, D.C., 1960, pp. 40-58.

6. "Pavement Management Guide," Roads and Transportation Association of Canada, Ottawa, 1977.

7. Finney, Edwin A., *Better Concrete Pavement Serviceability*, ACI Monograph No. 7, American Concrete Institute/Iowa State University Press, Detroit, 1973, 246 pp.

8. Darter, M. I.; Becker, J. M.; Snyder, M. B.; and Smith, R. E., "Portland Cement Concrete Pavement Evaluation Systems (COPES)," *NCHRP Report* No. 277, Transportation Research Board, Washington, D.C., Sept. 1985, 175 pp.

9. Sharma, J., and Stubstad, R. N., "Evaluation of Pavement in Florida by Using the Falling Weight Deflectometer," *Transportation Research Record* No. 755, Transportation Research Board, 1980, pp. 42-48.

10. Koole, R. C., "Overlay Design Based on Falling Weight Deflectometer Measurements," *Transportation Research Record* No. 700, Transportation Research Board, 1979, pp. 59-72.

11. Moore, W. M.; Hanson, D. I.; and Hall, J. W., Jr., "An Introduction to Nondestructive Structural Evaluation of Pavements," *Transportation Research Circular* No. 189, Transportation Research Board, Washington, D.C., Jan. 1978, 33 pp.

12. Brokaw, M. P., "Development of the Road Meter: 1965 to 1972," *Special Report* No. 133, Highway Research Board, Washington, D.C., 1973, pp. 17-19.

13. Spangler, E. B., and Kelly, W. J., "GRM Road Profilometer—A Method for Measuring Road Profiles," *Research Publication* No. GMR-452, Engineering Mechanics Department, General Motors Corporation, Dec. 1964.

14. Walker, R. S.; Roberts, F. L.; and Hudson, W. R., "A Profile Measuring, Recording, and Processing System," *Research Report* No. 73-2, Center for Highway Research, University of Texas at Austin, Apr. 1970.

15. Walker, R. S.; Hudson, W. R.; and Roberts, F. L., "Development of a System for High-Speed Measurement of Pavement Roughness, Final Report," *Research Report* No. 73-5F, Center for Highway Research, University of Texas at Austin, May 1971.

16. "Pavement Evaluation Using Road Meters," *Special Report* No. 133, Highway Research Board, Washington, D.C., 1973, 128 pp.

17. Walker, R. S., "Tentative Texas Highway Department Procedures for the Calibration Operation and Control of the Mays Road Meter," Center for Highway Research, University of Texas at Austin, Feb. 1972.

18. Haas, R., "Surface Evaluation of Pavements: State of the Art," *Proceedings*, Pavement Rehabilitation Workshop, TRB Report No. DOT-05-40022, Task Order 1, July 1974.

19. Smith, R. E., and Darter, M. I., "Highway Pavement Distress Identification Manual for Highway Condition and Quality of Highway Construction Survey," *Report* No. FHWA-RD-79-66, Federal Highway Administration, Washington, D.C., 1979, pp. 56-198.

This report was submitted to letter ballot of the committee which consists of 34 eligible members; 26 members returned their ballots, of whom 25 voted affirmatively and 1 abstained. 8 ballots were not returned.



APPENDIX B  
IDENTIFICATION AND CONTROL OF  
CONSOLIDATION-RELATED DEFECTS  
IN FORMED CONCRETE  
(ACI 309.2R-82)





# Identification and Control of Consolidation-Related Surface Defects in Formed Concrete

Reported by ACI Committee 309

ACI Committee Reports, Guides, Standard Practices, and Commentaries are intended for guidance in designing, planning, executing, or inspecting construction and in preparing specifications. Reference to these documents shall not be made in the Project Documents. If items found in these documents are desired to be part of the Project Documents they should be phrased in mandatory language and incorporated into the Project Documents.

*This report provides guidelines for identifying and controlling consolidation-related surface defects in precast or cast-in-place formed concrete. It includes a summary of direct and indirect causes of such defects, some of which are frequently attributed to inadequate consolidation practices. An outline to assist in the reporting on surface conditions and photographs to illustrate typical concrete surface defects are also included.*

*Surface defects may be minimized by proper planning during the design and specification stages. Of equal importance is the employment of properly trained and motivated supervisory and construction personnel to achieve the intended concrete finishes and surface textures.*

*The report emphasizes significant consolidation factors that prevent surface defects. The reader is cautioned that concrete is a hand crafted product; therefore, other potential causes may exist beyond those listed in this report.*

**Keywords:** aggregates; amplitude; concretes; consistency; consolidation; discoloration; formwork (construction); mix proportioning; placing; preplaced aggregate concrete; quality control; surface defects; temperature; vibration; voids; workability.

## CONTENTS

- 1.0 — General, p. 309.2R-1
- 2.0 — Factors Causing Defects, p. 309.2R-4
  - 2.1 — Design of Structural Members
  - 2.2 — Specifications
  - 2.3 — Forms
  - 2.4 — Properties of Fresh Concrete
  - 2.5 — Placement
  - 2.6 — Consolidation
  - 2.7 — Special Construction Conditions

## 3.0 — Surface Defects, p. 309.2R-6

- 3.1 — Honeycomb
- 3.2 — Air Surface Voids
- 3.3 — Form-Streaking
- 3.4 — Aggregate Transparency
- 3.5 — Subsidence Cracking
- 3.6 — Color Variation
- 3.7 — Sand Streaking
- 3.8 — Layer Lines
- 3.9 — Form Offsets
- 3.10 — Cold Joints

## 4.0 — Remedial Procedures, p. 309.2R-9

## 5.0 — Consolidation of Preplaced Aggregate Concrete, p. 309.2R-10

## 6.0 — Conclusion, p. 309.2R-10

## 7.0 — References, p. 309.2R-10

## 8.0 — ACI Standards and Reports Cited in the Text, p. 309.2R-11

## 9.0 — Surface Condition Outline, p. 309.2R-11

## 1.0 — GENERAL

A formed, uniformly smooth or lightly textured surface, essentially free of blemishes and color variation, is difficult to attain. Since repairs to a defective surface are costly and seldom fully satisfactory, they should be avoided by establishing and maintaining the quality of the concrete operation and by adhering to acceptable consolidation procedures. Standards for

Copyright © 1982 American Concrete Institute. All rights reserved including rights of reproduction and use in any form or by any means including the making of copies by any photo process, or by an electronic or mechanical device, printed or written or oral, or recording for sound or visual reproduction or for use in any knowledge or retrieval system or device, unless permission in writing is obtained from the copyright proprietors.



TABLE 1 — SUMMARY OF PRIMARY CAUSES OF SURFACE DEFECTS

Defects			Causes					
Name	Description	Figure	Design of Members 1	Forms 2	Construction Conditions 3	Properties of Fresh Concrete 4	Placement 5	Consolidation 6
Honeycomb	Stony surface with air voids; lacking in fines	1	Highly congested reinforcement, narrow section, configuration, internal interference, reinforcement splices	Leaking at joints, severe grout loss	High temperature, wind, reinforcement too close to forms, accessibility problems	Insufficient fines, low workability, early stiffening, excessive mixing, too large an aggregate for placing conditions	Excessive free fall, excessive travel of concrete in forms, too high a lift, drop chute omitted or insufficient length, too small a tremie, segregation	Vibrator too small, too low a frequency, too small an amplitude. Short immersion time, excessive spacing between immersions, inadequate penetration
Air Surface Voids	Small individual holes, irregular, usually ranging up to 1 inch (25 mm) in diameter	2	Battered or interfering construction	Form face impermeable, poor wetting characteristics, formwork too flexible, use of improper form oil	Excessive form oil, high temperature	Lean, sand with a high FM, low workability, low FM sand, excessive cement or pozzolan, particle degradation, excessive sand, high air content	Too slow, caused by inadequate pumping rate, undersized bucket	Too large an amplitude, external vibration inadequate, head of vibrator partially immersed
Form-streaking	Sand or gravel textured areas lacking cement, usually associated with dark color on adjacent surface	3		Leaking at joints, tie holes, etc.				Excessive amplitude or frequency
Aggregate transparency	Dark or light areas of similar size and shape to that of the coarse aggregate, mottled appearance	4		Too flexible, high density surface finish		Low sand content, gapgraded, aggregate dry or porous, excessive coarse aggregate, excessive slump with lightweight concrete		Excessive or external vibration; over-vibration of lightweight concrete
Absorbance cracking	Short cracks varying in width, more often horizontal than vertical	5	Interference to access	Poor thermal insulation, irregular shape restraining settlement, excessive absorbency	Insufficient interval between topout of columns and placement of slab or beam, low humidity	Low sand, high water content	Too rapid	Insufficient vibration



TABLE 1 (continued) — SUMMARY OF PRIMARY CAUSES OF SURFACE DEFECTS

Defects			Causes					
Name	Description	Figure	Design of Members 1	Forms 2	Construction Conditions 3	Properties of Fresh Concrete 4	Placement 5	Consolidation 6
Color Variation	Variations in color of the surface, visible within a few hours after removing the formwork	6	Heavy reinforcing close to forms	Variation in absorption capacity of surface, reaction with form face		Nonuniform color of materials, inconsistent grading, variation in proportions, incomplete mixing. Calcium chloride can cause dark streaks. Too high a slump. Over-manipulation	Segregation, failure to decrease consistency near the top of deep lift--	Vibrator too close to form, vibration next to forms variable
Sand Strreaking	Variation in color or shade due to separation of fine particles caused by bleeding parallel to the form face	7		Low absorbency	Low temperature, wet mixtures	Lean mixture, over-sanded bleeding mix, sand deficient in fines; low air content	Too rapid for type of mix	Excessive vibration. Excessive amplitude. Over-manipulation
Layer Lines	Dark colored scenes between concrete layers	8	Internal interference		Insufficient planning, high temperature	Wet mixture with tendency to bleed	Slow placement, lack of equipment or manpower	Lack of vibration, failure to penetrate into previous layer
Form Offsets	Abrupt to gradual surface irregularities	9		Inadequate stiffness or anchorage, weak forming material, irregular lumber, poor carpentry			Rate too high	Excessive amplitude, nonuniform spacing of immersion
Cold Joints	Unintended discontinuity, off-colored concrete	10	Internal interference		Poor planning or insufficient backup equipment	Too dry, early stiffening	Delayed delivery	Failure to vibrate into lower lift. Insufficient vibration

surface finishes are beyond the scope of this report. Guidance in establishing appropriate standards is offered by the International Council for Building Research (CIB).<sup>1</sup> The CIB guide classifies four types of surface finishes required in general concrete work, namely:

- Rough: No special requirement for finish
- Ordinary: Appearance is of some importance
- Elaborate: Definite requirements for visual appearance
- Special: Highest standards of appearance required

Concrete construction is not always providing the degree of perfection necessary to consistently obtain blemish-free concrete indicated by the special category.

To achieve any concrete finish, other than the tentative classification, the designer and contractor must use materials as well as design and construction practices that will keep the number of surface defects within tolerable limits. Surface defects may be traced to poor consolidation practices and to inadequate design or construction practices. Undesirable blemishes and/or defects encountered in concrete construction indicate a definite need for understanding their causes and for applying more effective measures to



ontrol or eliminate them. This report attempts to answer that need. Major emphasis is placed on consolidation-related defects.

## 1.0 — FACTORS CAUSING DEFECTS

Consolidation-related defects on formed concrete surfaces include:

(a) Design and Construction-Related Causes  
 Difficult placement due to design of a member.  
 Improper design and construction of forms.  
 Improper selection of concrete mixture proportions.  
 Failure to adjust concrete mixture proportions to suit placement condition.

Improper placement practices.  
 Improper vibration and consolidation practices.

(b) Equipment-Related Causes  
 Improper Equipment  
 Improper Equipment Maintenance

(c) Material-Related Causes  
 Improper selection of release agent.  
 Agent characteristics.

Variation in mixture components.  
 Inappropriate use of admixtures  
 Application procedures for release agents.

(d) Environmental Causes  
 Extreme weather conditions.

Table 1 summarizes categories of surface defects. Examples of some of the more common defects are illustrated in Fig. 1 through 10.

### 1.1 — Design of Structural Members

The common problems requiring consideration during design and planning are congested reinforcement (particularly splices), narrow sections, complex forms and conditions that require closed top forming, embedded forms, and battered forms.

The manner in which the concrete shall be placed and consolidated needs to be visualized for properly compacted members having the desired appearance. The designer must have a working knowledge of the concrete placement process. He and the constructor should communicate during the early phases of the concreting process. It is important to recognize problem areas in time to take appropriate remedial measures such as: staggering splices, grouping of bars, modifying stirrup spacing, and increasing the section size. When unfavorable conditions exist which could contribute to substandard surfaces, one or more of the following actions should be taken:

1. Redesign the member
2. Redesign the reinforcing steel
3. Specify special mixture modifications to meet unfavorable conditions
4. Utilize mock-up tests to develop a procedure
5. Alert the constructor to critical conditions

## 2.2 — Specifications

A good specification is essential to insure proper construction practices. Practical and workable specifications considering unusual and complex job conditions are likely to achieve the desired results.

Specifications must be sufficiently broad in scope to permit mixture proportion and batch adjustments needed to produce uniformly workable concrete which will respond readily to vibration. Concrete may still vary due to changes in aggregate gradation, air and concrete temperature, air content, yield, and batch weights, even though these changes are within established limits. Approved mixture proportions may need adjustments to produce the desired concrete characteristics and to minimize consolidation problems. Specifications should require recommended practices of mixing, transporting, handling, and placing that provide optimum consolidation and minimize chances for surface defects. Also, specifications must call for vibrators of proper size and characteristics that are in accordance with ACI 309.

## 2.3 — Forms

Some surface defects are caused by inadequacies of the formwork. Examples are leakage at joints, inadequate facing material, poorly braced and flexible forms, improper use of release agents, oversized and unsealed tie holes. Surface defects also result from overuse of forms, poor storage practices, inadequate cleaning, and improper patching and repair of the forms.

The number of visible surface voids may be reduced by using absorptive forms; however, smooth forms, in combination with the correct selection of a form release agent, allow air or water voids at formed surfaces to move upward more freely. ACI 303R discusses details of release agents.

Some dry resin type release agents on steel forms will greatly increase the number of bugholes. An excessive amount of release agent collecting in the bottom of the form may result in discoloration of the concrete and may create weak areas. Inadequately cleaned forms, or those which have been reused too many times, can contribute significantly to the formation of surface defects. When any of these conditions occur, peeling of the concrete surface may take place during form removal.

The finish produced by the form as it is stripped should be observed so that the appropriate corrective measure can be implemented expeditiously. Inward sloping forms have a tendency to trap or restrict the movement of air and water to the surface and increase the occurrence of bugholes.

Form strength, design, and other form requirements are covered in ACI 347.

## 2.4 — Properties of Fresh Concrete

The composition, consistency, workability, and temperature of fresh concrete have a significant bear-





ing on the ease with which a concrete mixture may be placed and consolidated. For critical surface finishes, the effect of each ingredient of the mixture may require special consideration. Mixture proportioning should also consider the placing conditions.

Furthermore, minor mixture adjustments should be made to maintain workability when the materials and field conditions change provided that the desired properties, such as durability, strength, etc., are maintained.

A review by the designer is essential to determine strength levels, maximum aggregate size, and slump requirements for different structural elements. A concrete specialist should be called on when difficult placing conditions exist or when particular concrete characteristics are desired.

Concrete ingredients should be evaluated and proportions should be selected well in advance of the concreting operation to achieve the desired properties for the fresh concrete. When the sand contains a large amount of particles passing the intermediate sieve sizes (Nos. 16, 30, 50) (1.2 mm, 600  $\mu$ m, 300  $\mu$ m), or when a high cement factor or a pozzolan is used, the resulting mixture may be sticky. Thus the passage of water may be restricted and air voids may form at the form-concrete interface. If the sand contains good fractions in the 30-50 range, little bleeding will occur in the resulting concrete. Also, the workability will tend to be good. As a result, placement and consolidation of the concrete will be facilitated, thereby minimizing surface defects.

Aggregates, particularly soft ones, should be evaluated for degradation during mixing. Such degradation can directly affect surface conditions and cause defects.

Experience indicates that a concrete at a given consistency will generally flow more easily at lower temperatures than at higher temperatures.

When admixtures are used, their effect on placement and consolidation should be evaluated when mixture proportions are being established. All of the above factors need to be considered to obtain a concrete mixture with the desired composition, consistency, and workability to facilitate its placement and consolidation.

## 2.5 — Placement

The objective is to place concrete with a minimum amount of segregation and splashing on the forms. Once the coarse aggregate is separated from the mortar by poor handling and placement practice, it is virtually impossible to work the mortar back into the voids and restore a dense mass by vibration. Segregation and separation causes honeycomb. Splattered mortar on the form produces color variations and poor surface texture. Placing concrete too slowly can produce lift lines or cold joints due to improper consolidation. The rate of placement and vibration factors (intensity, spacing) should be selected to minimize entrapped air in the concrete.

If concrete is deposited in thick lifts of more than 12 in. (305 mm) more air may be trapped than if it is placed in a thin, even layer of 6 in. (152 mm) thick or less. Where mixtures of dry or stiff consistencies are required, the placement should be spread in order to avoid bugholes and honeycombing.

## 2.6 — Consolidation

Concrete consists of coarse aggregate particles in a matrix of mortar and irregularly distributed pockets of entrapped air. The volume of entrapped air may vary from 5 to 20 percent depending on the workability of the mixture, size and shape of the form, amount of reinforcing steel, and method of depositing the concrete. The purpose of consolidation is to remove as much of this entrapped air as practical.

Vibration is the most common method of consolidation. It causes very rapid movement of the concrete mixture particles and momentarily liquifies the mixture, thus reducing the internal friction. When vibrated, concrete becomes unstable and through the action of gravity seeks a lower level and denser condition as entrapped air rises to the surface and is expelled. It compacts laterally against the form and around the reinforcing steel. As a field guide, vibration is continued until the entire batch melts to a uniform appearance and the surface just starts to glisten. A film of cement paste shall be discernable between the concrete and the forms. These visual indicators are not necessarily related to the amount of vibration needed to obtain good consolidation.

The effectiveness of the vibrator is largely governed by the head diameter, frequency, and amplitude.

Undervibration is far more common than overvibration, and may be caused by:

1. Use of an undersized or underpowered vibrator or one not in good working order.
2. Excessive or haphazard spacing of insertions.
3. Inadequate duration of each insertion.
4. Failure of the vibrator to penetrate into the preceding layer.
5. Vibrator in the wrong position relative to the form.

Common imperfections resulting from undervibration are honeycomb, excessive air voids, and layer lines.

Overvibration can occur when the vibration time is several times the recommended amount. Overvibration generally is the result of using oversized equipment, improper procedures, too high slump, or heavy aggregates. It may result in segregation, excessive form deflection, sand streaking, form damage, or loss of almost all of the entrained air in the concrete; however, the concrete is not likely to be seriously affected by overvibration if a well-proportioned mixture with a proper slump is used. The behavior of fresh concrete during vibration is discussed in ACI 309.1R.



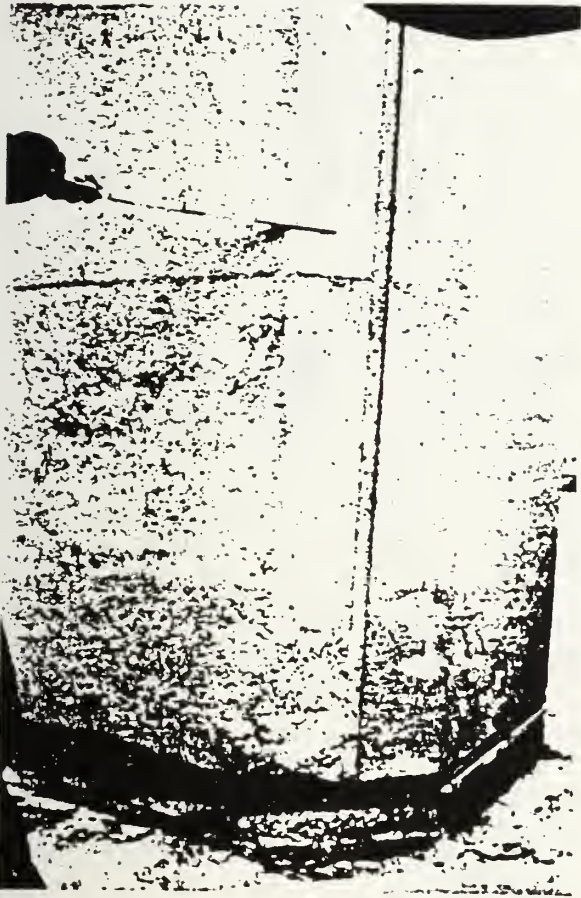

Fig. 1 — Honeycomb.

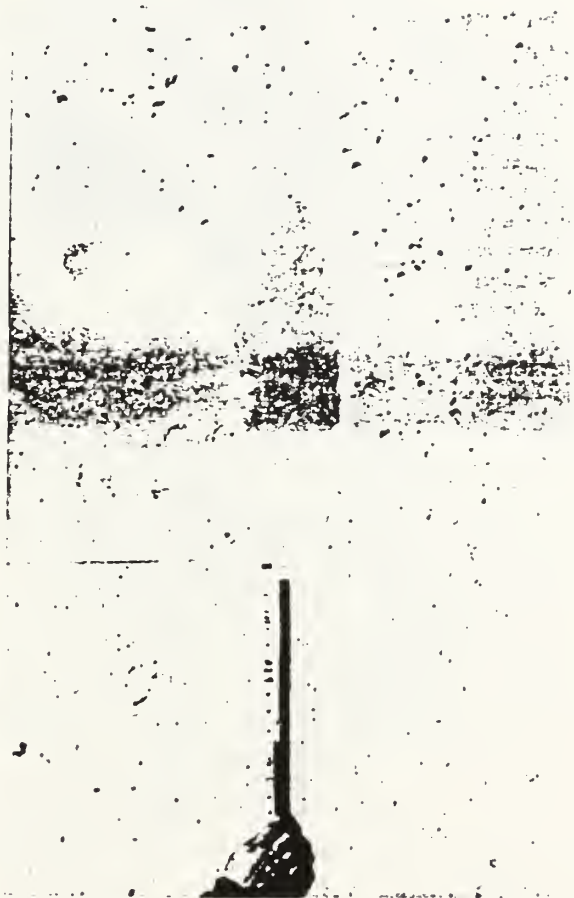

Fig. 2 — Air surface voids.

## 2.7 — Special Construction Conditions

No matter how carefully a concrete finish is specified, the resultant quality depends on careful construction site organization and the use of well-trained and skilled workmen. Competent supervision is essential to assure that the construction forces properly handle and assemble the forms and methodically place and consolidate the concrete.

Formed concrete surfaces under boxouts and battered forms require special considerations for placement. The mixture may have to be adjusted to produce a readily flowable concrete that is capable of completely filling the formed area. For large surface areas, it may be necessary to cut holes in a battered form to provide access for vibrating the concrete. With thin lifts and careful vibration, the air and water bubbles can be drawn up the side of the form. Experience shows that sloped concrete steeper than about 20 deg should be formed and the concrete thoroughly vibrated to minimize surface voids. Sloping forms at angles about 45 deg or less may be erected as temporary forms that are removed for later hand finishing of the concrete.

Large mass concrete sections placed in irregularly shaped forms may have surface defects due to non-

uniform or widely spaced locations for elephant trunks, pipes, or chutes. Thoughtless procedures can cause the concrete to build up in piles. This will promote segregation, cold joints, layer lines, and subsidence cracks. Placing methods should be well planned by the constructor.

## 3.0 — SURFACE DEFECTS

The most serious defects resulting from ineffective consolidation procedures are: honeycomb, subsidence cracks, layer lines, and excessive surface voids. A detailed description of defects and their causes is listed in Table 1.

### 3.1 — Honeycomb

(Fig. 1) is a surface condition of irregular voids due to failure of the mortar during vibration to effectively fill the spaces among coarse aggregate spaces. Where bridging of the aggregate particles, or stiffness of the mixture is a cause of honeycomb, vibration may assist in overcoming the bridging or to change the flowability of the concrete. Factors that may contribute to honeycombing are: congested reinforcement, insufficient paste content, improper sand-aggregate ratio, improper placing techniques, and difficult construction conditions.





Fig. 3 - Form-streaking.



Fig. 4 - Aggregate transparency



Fig. 5 - Subsidence cracking.



Fig. 6 - Color variation.





Fig. 7 — Sand streaking.



Fig. 8 — Layer lines.

### 3.2 — Air Surface Voids (Bugholes)

(Fig. 2) on vertical faces are caused by air bubbles entrapped between the concrete mass and the form, especially in sticky, or stiff concrete mixtures of low workability which may have an excessive sand and/or air content.<sup>4</sup> Also, the use of vibrators of too large an amplitude or when the vibrator head is only partially submerged may result in increased void formation. Air voids vary in size from microscopic to about 0.5 in. (12.7 mm). Rarely will water create bugholes on formed surfaces which manifests itself in other textural defects such as bleeding channels or sand streaks. Bleed water voids can form at the top of a column and on battered formed surfaces. Remedial procedures discussed later can greatly reduce such blemishes.

### 3.3 — Form-Streaking

(Fig. 3) results from mortar leaking at form joints and is frequently aggravated by overvibration using vibrators that are too powerful, or using forms that are too weak or ones that vibrate excessively during consolidation. Placing excessively wet mixtures or high-slump concrete will result in the wash out of more mortar through tie holes and loose fitting forms than placement of a low slump concrete mixture.

### 3.4 — Aggregate Transparency

(Fig. 4) may result from the use of concrete mixtures with low sand content, dry or porous aggregates, high density or glossy form surfaces, or high slump with some lightweight and normal weight aggregates.

### 3.5 — Subsidence Cracking

(Fig. 5) results from the development of tension when the concrete mechanically settles after or near initial set. The cracks are caused by concrete which is not capable of bridging. They may occur when there is an insufficient interval between topout of concrete in columns and placement of concrete for slabs or beams. They may also occur adjacent to blockouts. To prevent this type of cracking, the concrete should be revibrated in these areas about 1 hr after placement.

### 3.6 — Color Variation

(Fig. 6) may occur within a placement if the concrete is not uniform or is incompletely mixed. Vibrators inserted too close to the form destroy the parting agent or mar the form surface. External vibration used haphazardly may also cause color variation. Furthermore, color variations may also result from non-uniform absorption and/or nonuniform application of the release agent.

### 3.7 — Sand Streaking

(Fig. 7) is caused by heavy bleeding along the form. It frequently results from the use of harsh, wet mixtures deficient in cement paste or mixtures contain-







Fig. 9 - Form offsets.



Fig. 10 - Cold joints.

ing poorly graded aggregates — particularly those deficient in No. 50 to No. 100 (300 to 150  $\mu\text{m}$ ) and smaller sizes. Sand streaking is controlled by assuring tight forms, well-graded fines, and low bleeding through proper mixture proportioning. Although the characteristics of portland cement and fly ash, if used, have some influence on bleeding, the grading of the fine aggregate, and the properties of the grout fluidifiers are of greater importance. Streaking tendencies are amplified as the proportion of sand to cementing materials increase, as in lean mixtures.

**3.8 - Layer Lines**

(Fig. 8) are the dark horizontal lines on formed surfaces indicating the boundary between concrete placements caused by stiffening of the lower level or insufficient consolidation due to lack of penetration into the lower level with the vibrator.

**3.9 - Form Offsets**

(Fig. 9) are caused by inadequate stiffness or anchorage of the forms and can be aggravated by too high a rate of placement and/or using too powerful a vibrator.

**3.10 - Cold Joints**

(Fig. 10) frequently occur in concrete due to poor planning, insufficient backup equipment, stiffening of the in-place concrete mixture, and an inability to vibrate into lower lifts.

**4.0 - REMEDIAL PROCEDURES**

A number of studies have been made to achieve better consolidation resulting in fewer surface voids.<sup>15</sup> To minimize the size and number of surface voids the following practices should be followed:

- Vibration period of sufficient duration
- Vibrator insertions properly spaced and overlapped and the vibrator removed slowly
- Each concrete layer consolidated from the bottom upward
- Increased vibration periods when using impermeable forms
- Avoidance of inward sloping forms and other complex design details
- Limited depth of lifts
- Vibrator penetration into the previous lift

Surface air voids can be minimized by the use, where practical, of a 2½ in. (64 mm) diameter vibra-



tor of high frequency with medium to low amplitude. The vibrator should be immersed in the concrete around the perimeter of the form without touching the form wall. Form vibration may be used to supplement the internal vibration. An alternate procedure is to use a high frequency, low amplitude form vibrator. Vibration procedures should be evaluated at the beginning of a project to determine the vibration time for each type of vibrator for a given mixture.

Revibration may also reduce concrete surface voids, which can be accomplished where voids are most prevalent. It will be most effective if revibration is delayed as late as possible in the setting period of the concrete. Greater benefits are obtained from the wetter concrete mixtures, especially in the top few feet of a placement where air and water voids are most prevalent. Revibration should not be applied routinely, however, and only if special form design is provided.

### 5.0 — CONSOLIDATION OF PREPLACED AGGREGATE CONCRETE

The causes and cures of defects in concrete produced by the preplaced aggregate concrete method\* (PA) are different from conventionally mixed and placed concrete in certain aspects. Also, refer to ACI 304.1R.

The rate of grout rise in preplaced aggregate should be limited to an average of 1 ft-per-min (0.3 m/min) with a maximum of 2 ft-per-min (0.6 m/min). If the supply is too rapid, the grout will rise faster through the large voids and cascade into the smaller ones, trapping air. The result is spotty honeycombing. To avoid the occurrence of layer lines, the lower ends of the grout inserts should always be maintained at least 1 to 2 ft (0.3 to 0.6 m) below the grout surface.

Grout will not penetrate pockets of fine aggregate; fines that collect against side or bottom forms will produce honeycombing. Also, care should be taken to insure that coarse aggregate fills the space between reinforcement and forms. Large surface areas of grout not subdivided by coarse aggregate may show crazing from drying shrinkage.

Coarse aggregate should be saturated when placed and at the time it is grouted. If rewetting in the forms is required, a fog spray may be applied sparingly. Larger quantities of water will wash fines to the bottom, resulting in a poor surface or honeycomb.

Forms vibrated lightly with external vibrators permit the grout to cover the points of coarse aggregate in contact with the form. Overvibration of the form should be avoided, however, as it will induce bleeding which may result in sand streaking.

Where the appearance of formed surfaces is important, a test section of comparable height should be produced, the surface examined, and adjustments made to grading, placing, and consolidation procedures to obtain an acceptable result.

### 6.0 — CONCLUSION

Faulty design and construction practices can result in defects in formed concrete surfaces. To keep these defects within tolerable limits, an awareness of their causes and their cures is essential. The causes of these defects may lie in materials selection, placement, consolidation, workmanship, initial design concepts, or specifications. In general, to obtain a C.I.B. finish of elaborate or special category requires the services of a concrete specialist who can anticipate complex placing problems and who will provide specifications and instruction. Finally, the execution of the work by well-trained work crews under competent supervision will ensure a concrete surface meeting the requirements of the owner or designer.

### 7.0 — REFERENCES

1. "Tolerances on Blemishes of Concrete," *CIB Report No. 24*, International Council for Building Research Studies and Documentation, Rotterdam, 1975, 8 pp.
2. ACI Committee 309, "Recommended Practice for Consolidation of Concrete (ACI 309-72)(Reaffirmed 1978)," American Concrete Institute, Detroit, 1972, 40 pp. Also, *ACI Manual of Concrete Practice*, Part 2.
3. ACI Committee 303, "Guide to Cast-in-Place Architectural Concrete Practice," (ACI 303R-74), American Concrete Institute, Detroit, 1974, 30 pp. Also, *ACI Manual of Concrete Practice*, Part 3.
4. ACI Committee 347, "Recommended Practice for Concrete Formwork (ACI 347-78)," American Concrete Institute, Detroit, 1978, 37 pp. Also, *ACI Manual of Concrete Practice*, Part 2.
5. Shilstone, James M., "Surface Blemishes in Formed Concrete," *Proceedings, RILEM/ASTM/CIB Symposium on Performance Evaluation of External Vertical Surfaces of Buildings* (Otaniemi, Espoo, Aug.-Sept. 1977), Technical Research Centre of Finland, Espoo, 1977, pp. 3-7.
6. Stamenkovic, Hrista, "Surface Voids Can Be Controlled," *Concrete Construction*, V. 18, No. 12, Dec. 1973, pp. 597-598, 600.
7. Samuelson, Paul, "Voids in Concrete Surfaces," *ACI JOURNAL, Proceedings* V. 67, No. 11, Nov. 1970, pp. 868-874.
8. Reading, Thomas J., "The Bughole Problem," *ACI JOURNAL, Proceedings* V. 69, No. 3, Mar. 1972, pp. 165-171.
9. ACI Committee 304, "Preplaced Aggregate Concrete for Structural and Mass Concrete," (ACI 304.1R-69), American Concrete Institute, Detroit, 1969, 13 pp. Also, *ACI Manual of Concrete Practice*, Part 2.
10. King, John C., "Special Concretes and Mortars," *Handbook of Heavy Construction*, 2nd Edition, McGraw-Hill Book Company, New York, 1971, pp. 22-1 to 22-17.



**8.0 — ACI STANDARDS AND REPORTS CITED IN THE TEXT**

(American Concrete Institute, P.O. Box 19150, Detroit, Michigan 48219) The standards and reports referred to in this document are listed below with their serial designation, including year of adoption or revision. The standards and reports listed were the latest effort at the time this document was written. Since some of these publications are revised frequently, generally in minor details only, the user of this document should check directly with the sponsoring group if it is desired to refer to the latest revision.

ACI 303R-74, Guide to Cast-In-Place Architectural Concrete Practice

ACI 304.1R-69, Preplaced Aggregate Concrete for Structural and Mass Concrete

ACI 309-72 (Reaffirmed 1978), Recommended Practice for Consolidation of Concrete

ACI 309.1R-81, Behavior of Fresh Concrete During Vibration

ACI 347-78, Recommended Practice for Concrete Formwork

**9.0 — SURFACE CONDITION OUTLINE**

**1 — Description of structure**

- 1.1 — Name, location, type, and size
- 1.2 — Owner, project engineer, contractor
- 1.3 — Design
  - 1.3.1 — Architect and/or engineer
- 1.4 — Photographs
  - 1.4.1 — General view

**2 — Description of wall, beam, or column showing defect**

- 2.1 — Location, size
- 2.2 — Type of concrete
  - 2.2.1 — Architectural
  - 2.2.2 — Structural

**3 — Defect**

- 3.1 — Name
  - 3.1.1 — Description
  - 3.1.2 — Photographs

**4 — Causes**

- 4.1 — Design of member

- 4.1.1 — Reinforcement (spacing and frequency)
- 4.1.2 — Width, depth
- 4.1.3 — Configuration
- 4.2 — Forms
  - 4.2.1 — Method
  - 4.2.2 — Shape
  - 4.2.3 — Insulation
  - 4.2.4 — Material type, new or used
  - 4.2.5 — Form coatings
  - 4.2.6 — Texture or finish
  - 4.2.7 — Tightness
  - 4.2.8 — Structural Adequacy
- 4.3 — Construction conditions
  - 4.3.1 — Temperature
  - 4.3.2 — Wind
  - 4.3.3 — Humidity
  - 4.3.4 — Precipitation
  - 4.3.5 — Placing accessibility
  - 4.3.6 — Precautions, covered in 4.5
- 4.4 — Properties of fresh concrete
  - 4.4.1 — Proportions
  - 4.4.2 — Workability
  - 4.4.3 — Gradations
  - 4.4.4 — Consistency
  - 4.4.5 — Aggregate maximum size
  - 4.4.6 — Cohesion
  - 4.4.7 — Air content
- 4.5 — Placement
  - 4.5.1 — Rate
  - 4.5.2 — Conditions
  - 4.5.3 — Adequacy of equipment
- 4.6 — Consolidation
  - 4.6.1 — Frequency
  - 4.6.2 — Amplitude
  - 4.6.3 — Physical size
  - 4.6.4 — Schedule of insertions
  - 4.6.5 — Number of units
  - 4.6.6 — Depth of penetration
  - 4.6.7 — Length of vibration

This report was submitted to letter ballot of the committee which consists of 15 members: 14 were affirmative and 1 was not returned.

**ACI Committee 309  
Consolidation of Concrete**

**Ralph O. Lane  
Chairman**

**George R. Burg  
Lars Forssblad  
Gordon M. Kidd  
John C. King  
Gary R. Mass**

**Sandor Popovics  
Thomas J. Reading  
Kenneth L. Saucier  
Donald L. Schlegel**

**James M. Shilstone  
John R. Smith\*  
Clem H. Spitler  
Herbert A. Welton  
Roger E. Wilson**

\*Task force leader



APPENDIX C  
CAUSES, EVALUATION, AND REPAIR  
OF CRACKS IN CONCRETE STRUCTURES  
(ACI 224.1R-89)





# Causes, Evaluation, and Repair of Cracks in Concrete Structures

Reported by ACI Committee 224

ACI Committee Reports, Guides, Standard Practices, and Commentaries are intended for guidance in designing, planning, executing, or inspecting construction and in preparing specifications. Reference to these documents shall not be made in the Project Documents. If items found in these documents are desired to be part of the Project Documents, they should be phrased in mandatory language and incorporated into the Project Documents.

*The causes of cracks in concrete structures are summarized. The procedures used to evaluate cracking in concrete and the principal techniques for the repair of cracks are presented. Evaluation techniques and criteria are described. The key methods of crack repair are discussed, and guidance is provided for their proper application.*

**Keywords:** autogenous healing; beams (supports); cement-aggregate reactions; concrete construction; concrete pavements; concrete slabs; concretes; consolidation; corrosion; cracking (fracturing); drilling; drying shrinkage; epoxy resins; evaluation; failure; grouting; heat of hydration; mass concrete; mix proportioning; plastics, polymers, and resins; precast concrete; prestressed concrete; reinforced concrete; repairs; resurfacing; sealing; settlement (structural); shrinkage; specifications; structural design; tension; thermal expansion; volume change.

## CONTENTS

Preface, page 224.1R-1

Chapter 1 — Causes and control of cracking, page 224.1R-1

- 1.1 — Introduction
- 1.2 — Cracking of plastic concrete
- 1.3 — Cracking of hardened concrete

Chapter 2 — Evaluation of cracking, page 224.1R-8

- 2.1 — Introduction
- 2.2 — Determination of location and extent of cracking
- 2.3 — Selection of repair procedures

Chapter 3 — Methods of crack repair, page 224.1R-12

- 3.1 — Introduction
- 3.2 — Epoxy injection
- 3.3 — Routing and sealing
- 3.4 — Stitching
- 3.5 — Additional reinforcement
- 3.6 — Drilling and plugging
- 3.7 — Flexible sealing
- 3.8 — Grouting
- 3.9 — Drypacking
- 3.10 — Crack arrest
- 3.11 — Polymer impregnation
- 3.12 — Overlays and surface treatments
- 3.13 — Autogeneous healing

Chapter 4 — Summary, page 224.1R-18

Chapter 5 — References, page 224.1R-18

- 5.1 — Recommended references
- 5.2 — Cited references

## PREFACE

Cracks in concrete have many causes. They may affect appearance only, or they may indicate significant structural distress or a lack of durability. Cracks may represent the total extent of the damage, or they may point to problems of greater magnitude. Their significance depends on the type of structure, as well as the nature of the cracking. For example, cracks that are acceptable for building structures may not be acceptable in water-retaining structures.

The proper repair of cracks depends upon knowing the causes and selecting the repair procedures that take these causes into account; otherwise, the repair may only be temporary. Successful long-term repair procedure must attack the causes of the cracks as well as the cracks themselves.

To aid the practitioner in pinpointing the best solution to a cracking problem, this report discusses the causes, evaluation procedures, and methods of repair of cracks in concrete. Chapter 1 presents a summary of the causes of cracks and is designed to provide background for the evaluation of cracks. Chapter 2 describes evaluation techniques and criteria. Chapter 3 describes the methods of crack repair and includes a discussion of a number of the techniques that are available. Many situations will require a combination of methods to fully correct the problem.

## CHAPTER 1 — CAUSES AND CONTROL OF CRACKING

### 1.1 — Introduction

This chapter presents a brief summary of the causes of cracks and means for their control. Cracks are categorized as either occurring in plastic concrete or occur-

Copyright © 1989, American Concrete Institute. All rights reserved including rights of reproduction and use in any form or by any means, including the making of copies by any photo process, or by any electronic or mechanical device, printed or written or oral, or recording for sound or visual reproduction or for use in any knowledge or retrieval system or device, unless permission in writing is obtained by the copyright proprietors.



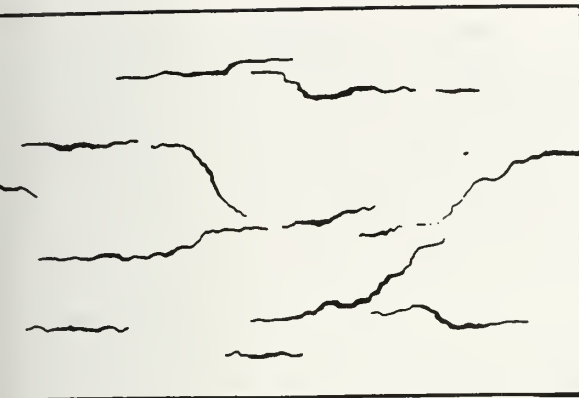

1.1—Typical plastic shrinkage cracking (Reference 1)

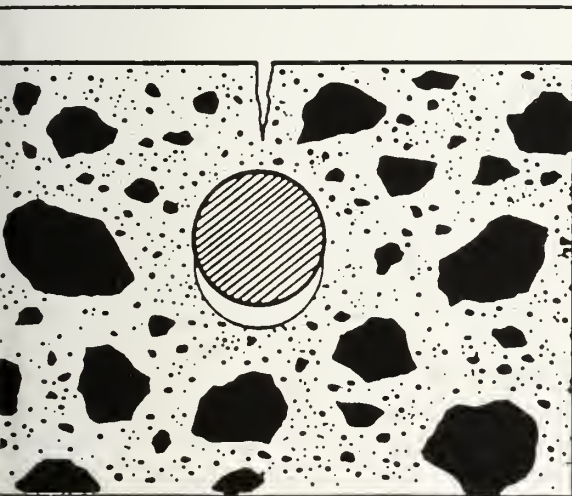

1.2—Crack formed due to obstructed settlement (Reference 2)

in hardened concrete.<sup>1,2</sup> In addition to the information provided here, further details are presented in a report by this committee (ACI 224R) and articles by Kelly,<sup>1</sup> Price,<sup>2</sup> Carlson et al.,<sup>3</sup> and Abdun-Nur.<sup>4</sup> Additional references are cited throughout the chapter.

**Cracking of plastic concrete**

**1.1 Plastic shrinkage cracking** — Plastic shrinkage cracking in concrete (Fig. 1.1) occurs most commonly on the exposed surfaces of freshly placed floors and walls (or other elements with large surface areas) when subjected to a very rapid loss of moisture caused by low humidity, wind, and/or high temperature. Plastic shrinkage usually occurs prior to final finishing, before curing starts.

When moisture evaporates from the surface of freshly placed concrete faster than it is replaced by bleed water, the surface concrete shrinks. Due to the restraint provided by the concrete below the drying surface layer, tensile stresses develop in the weak, stiff plastic concrete, resulting in shallow cracks that are usually short and run in all directions. These cracks are often fairly wide at the surface. They range from a few inches to many feet in length and are spaced from

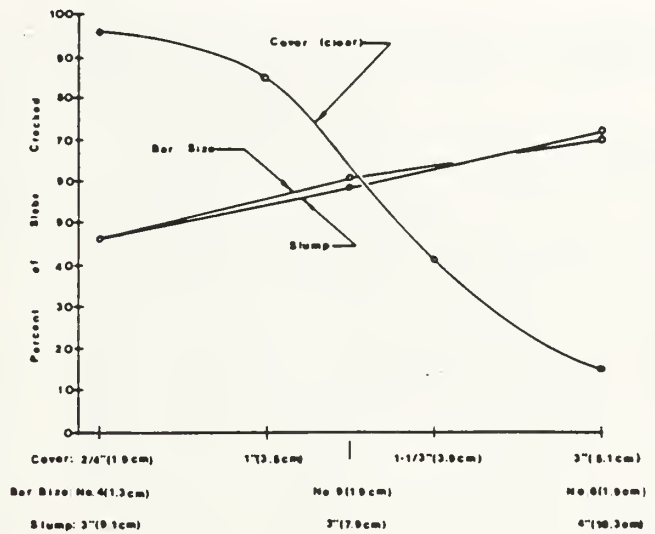

Fig. 1.3—Settlement cracking as a function of bar size, slump, and cover (Reference 5)

a few inches to as much as ten feet (3 m) apart. Plastic shrinkage cracks may extend the full depth of elevated structural slabs.

Since plastic shrinkage cracking is due to a differential volume change in the plastic concrete, successful control measures require a reduction in the relative volume change between the surface and other portions of the concrete.

Steps can be taken to prevent a rapid moisture loss due to hot weather and dry winds (ACI 224R, ACI 302.1R, ACI 305R). These measures include the use of fog nozzles to saturate the air above the surface and the use of plastic sheeting to cover the surface between the final finishing operations. Windbreaks to reduce the wind velocity and sunshades to reduce the surface temperature are also helpful, and it is good practice to schedule flat work after the walls have been erected. Measures that increase the rate of bleeding may also be helpful.

**1.2.2 Settlement cracking** — After initial placement, vibration, and finishing, concrete has a tendency to continue to consolidate. During this period, the plastic concrete may be locally restrained by reinforcing steel, a prior concrete placement, or formwork. This local restraint may result in voids and/or cracks adjacent to the restraining element (Fig. 1.2). When associated with reinforcing steel, settlement cracking increases with increasing bar size, increasing slump, and decreasing cover.<sup>5</sup> This is shown in Fig. 1.3 for a limited range of these variables. The degree of settlement cracking may be magnified by insufficient vibration or the use of leaking or highly flexible forms.

Proper form design (ACI 347) and adequate vibration (and revibration), provision of a sufficient time interval between the placement of concrete in columns and the placement of concrete in slabs and beams (ACI 309.2R), the use of the lowest possible slump, and an increase in concrete cover will reduce settlement cracking.



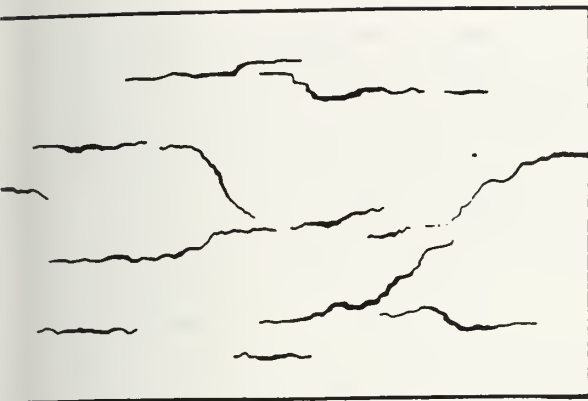

1.1—Typical plastic shrinkage cracking (Reference 1)

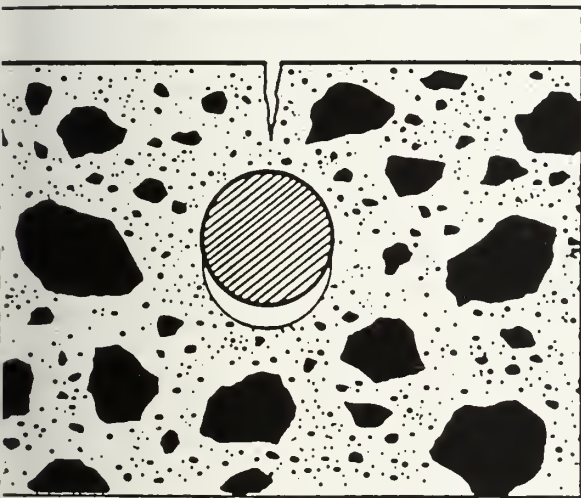

1.2—Crack formed due to obstructed settlement (Reference 2)

in hardened concrete.<sup>1,2</sup> In addition to the information provided here, further details are presented in a report by this committee (ACI 224R) and article by Kelly,<sup>1</sup> Price,<sup>2</sup> Carlson et al.,<sup>3</sup> and Abdun-Nur.<sup>4</sup> Additional references are cited throughout the chapter.

— Cracking of plastic concrete

2.1 Plastic shrinkage cracking — Plastic shrinkage cracking in concrete (Fig. 1.1) occurs most commonly on the exposed surfaces of freshly placed floors and walls (or other elements with large surface areas) when subjected to a very rapid loss of moisture caused by low humidity, wind, and/or high temperature. Plastic shrinkage usually occurs prior to final finishing, before setting starts.

When moisture evaporates from the surface of freshly placed concrete faster than it is replaced by bleed water, the surface concrete shrinks. Due to the restraint provided by the concrete below the drying surface layer, tensile stresses develop in the weak, stiff plastic concrete, resulting in shallow cracks that are usually short and run in all directions. These cracks are often fairly wide at the surface. They range from a few inches to many feet in length and are spaced from

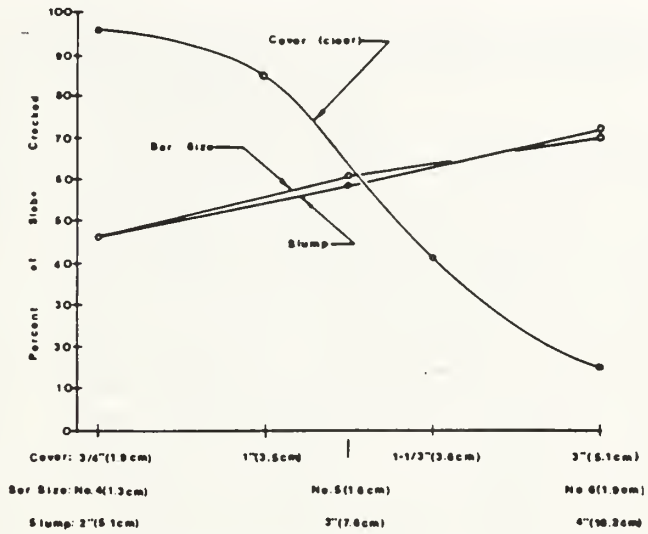

Fig. 1.3—Settlement cracking as a function of bar size, slump, and cover (Reference 5)

a few inches to as much as ten feet (3 m) apart. Plastic shrinkage cracks may extend the full depth of elevated structural slabs.

Since plastic shrinkage cracking is due to a differential volume change in the plastic concrete, successful control measures require a reduction in the relative volume change between the surface and other portions of the concrete.

Steps can be taken to prevent a rapid moisture loss due to hot weather and dry winds (ACI 224R, ACI 302.1R, ACI 305R). These measures include the use of fog nozzles to saturate the air above the surface and the use of plastic sheeting to cover the surface between the final finishing operations. Windbreaks to reduce the wind velocity and sunshades to reduce the surface temperature are also helpful, and it is good practice to schedule flat work after the walls have been erected. Measures that increase the rate of bleeding may also be helpful.

1.2.2 Settlement cracking — After initial placement, vibration, and finishing, concrete has a tendency to continue to consolidate. During this period, the plastic concrete may be locally restrained by reinforcing steel, a prior concrete placement, or formwork. This local restraint may result in voids and/or cracks adjacent to the restraining element (Fig. 1.2). When associated with reinforcing steel, settlement cracking increases with increasing bar size, increasing slump, and decreasing cover.<sup>5</sup> This is shown in Fig. 1.3 for a limited range of these variables. The degree of settlement cracking may be magnified by insufficient vibration or the use of leaking or highly flexible forms.

Proper form design (ACI 347) and adequate vibration (and revibration), provision of a sufficient time interval between the placement of concrete in columns and the placement of concrete in slabs and beams (ACI 309.2R), the use of the lowest possible slump, and an increase in concrete cover will reduce settlement cracking.



### 1.3 — Cracking of hardened concrete

**1.3.1 Drying shrinkage** — A common cause of cracking in concrete is restrained drying shrinkage. Drying shrinkage is caused by the loss of moisture from the cement paste constituent, which can shrink by as much as 1 percent per unit length. Fortunately, aggregate provides internal restraint that reduces the magnitude of this volume change to about 0.05 percent. On wetting, concrete tends to expand.

These moisture-induced volume changes are a characteristic of concrete. If the shrinkage of concrete could take place without any restraint, the concrete would not crack. It is the combination of shrinkage and restraint (usually provided by another part of the structure or by the subgrade) that causes tensile stresses to develop. When the tensile strength of concrete is exceeded, it will crack. Cracks may propagate at much lower stresses than are required to cause crack initiation.

In massive concrete elements, tensile stresses are caused by differential shrinkage between the surface and the interior concrete. The larger shrinkage at the surface causes cracks to develop that may, with time, penetrate deeper into the concrete.

Magnitude of the tensile stresses is influenced by a combination of factors, including the amount of shrinkage, the degree of restraint, the modulus of elasticity, and the amount of creep. The amount of drying shrinkage is influenced mainly by the amount and type of aggregate and the water content of the mix. The greater the amount of aggregate, the smaller the amount of shrinkage.<sup>6</sup> The higher the stiffness of the aggregate, the more effective it is in reducing the shrinkage of the concrete (i.e., the shrinkage of concrete containing sandstone aggregate may be more than twice that of concrete with granite, basalt, or limestone<sup>7</sup>). The higher the water content, the greater the amount of drying shrinkage.<sup>8</sup>

Surface crazing on walls and slabs is an excellent example of drying shrinkage on a small scale. Crazing usually occurs when the surface layer of the concrete has a higher water content than the interior concrete. The result is a series of shallow, closely spaced, fine cracks.

Drying shrinkage can be reduced by using the maximum practical amount of aggregate in the mix. The lowest usable water content is desirable. A procedure that will help reduce settlement cracking, as well as drying shrinkage in walls, is reducing water content of the concrete as the wall is placed from the bottom to the top. Using this procedure, bleed water from the lower portions of the wall will tend to equalize the water content within the wall. To be successful, this procedure needs careful control and proper consolidation.

Shrinkage cracking can be controlled by using properly spaced contraction joints and proper steel detailing. Shrinkage cracking may also be controlled using shrinkage-compensating cement. It is worthy of note that in cases where crack control is particularly important, the minimum requirements of ACI 318 are not always adequate. These points are discussed in greater

detail in ACI 224R, which contains other construction practices designed to help control the drying shrinkage cracking that does occur.

**1.3.2 Thermal stresses** — Temperature differences within a concrete structure may be due to cement hydration or changes in ambient conditions or both. These temperature differences result in differential volume changes. When the tensile strains due to the differential volume changes exceed their tensile strain capacity, concrete will crack. The effects of temperature differentials due to the hydration of cement are normally associated with mass concrete (which can include large columns, piers, beams, and footings, as well as dams), while temperature differentials due to changes in the ambient temperature can affect any structure.

Considering thermal cracking in mass concrete, portland cement liberates heat as it hydrates, causing the internal temperature of concrete to rise during the initial curing period. The concrete rapidly gains both strength and stiffness as cooling begins. Any restraint of the free contraction during cooling will result in tensile stress. Tensile stresses developed during the cooling stage are proportional to the temperature change, the coefficient of thermal expansion, the effective modulus of elasticity (which is reduced by creep), and the degree of restraint.<sup>9-11</sup> The more massive the structure, the greater the potential for temperature differential and degree of restraint.

Procedures to help reduce thermally induced cracking include reducing the maximum internal temperature, delaying the onset of cooling, controlling the rate at which the concrete cools, and increasing the tensile strain capacity of the concrete. These and other methods used to reduce cracking in mass concrete are presented in ACI 207.1R, ACI 207.2R, and ACI 224R.

Hardened concrete has a coefficient of thermal expansion that may range from 4 to  $6 \times 10^{-6}/F$  (7 to  $11 \times 10^{-6}/C$ ), with an average of  $5.5 \times 10^{-6}/F$  ( $10 \times 10^{-6}/C$ ). When one portion of a structure is subjected to a temperature induced volume change, the potential for thermally induced cracking exists. Designers should give special consideration to structures in which some portions are exposed to temperature changes, while other portions of the structure are either partially or completely protected. A drop in temperature may result in cracking in the exposed element, while increases in temperature may cause cracking in the protected portion of the structure. Temperature gradients cause deflection and rotation in structural members; if restrained, serious stresses can result.<sup>12,13</sup> Allowing for movement by using properly designed contraction joints and correct detailing will help alleviate these problems.

**1.3.3. Chemical reactions** — A number of deleterious chemical reactions may result in the cracking of concrete. These reactions may be due to the aggregate used to make the concrete or materials that come into contact with the concrete after it has hardened.

Some general concepts for reducing adverse chemical reactions are presented, but only pretesting of the final





ure or extended field experience will determine the effectiveness of a specific measure.

Concrete may crack as the result of expansive reactions between aggregate containing active silica and alkalis derived from cement hydration, admixtures, or natural sources (e.g., curing water, ground water, alkaline solutions stored or used in the finished structure).

The alkali-silica reaction results in the formation of a siliceous gel, which tends to draw water from other portions of the concrete. This causes local expansion accompanied by tensile stresses, and may eventually result in the complete deterioration of the structure. Control measures include proper selection of aggregate, use of low alkali cement, and use of pozzolans, which themselves contain very fine, highly active silica. The first measure may preclude the problem from arising, while the latter two measures have the effect of decreasing the alkali to reactive silica ratio, resulting in the formation of a nonexpanding calcium alkali silicate.

Certain carbonate rocks participate in reactions with alkalis which, in some instances, produce detrimental expansion and cracking. These determined alkali-carbonate reactions are usually associated with argillaceous dolomitic limestones which have somewhat unusual textural characteristics (ACI 201.2R). The affected concrete is characterized by a network pattern of cracks. The reaction is distinguished from the alkali-silica reaction by the general absence of silica surface deposits at the crack. The problem may be minimized by avoiding reactive aggregates, dilution with non-reactive aggregates, use of a smaller maximum size aggregate, and use of low alkali cement (ACI 201.2R).

Sulfate-bearing waters are a special durability problem for concrete. When sulfate penetrates hydrated cement paste, it comes in contact with hydrated calcium silicate. Calcium sulfoaluminate is formed, with a frequently large increase in volume, resulting in high tensile stresses causing the concrete to deteriorate. Type II and V portland cement, which are low in trisulfate aluminate, will reduce the severity of the problem. The blended cements specified in ASTM C 595 are useful in this regard. In severe cases, pozzolans, which are known to impart additional resistance to sulfate attack, could be used after adequate testing.

Similar conditions may also occur from the application of deicing salts to the surface of hardened concrete. Concrete subjected to water soluble salts should be amply air entrained, have adequate cover over the reinforcing steel, and be made of high-quality, low permeability concrete. The effects of these and other problems relating to the durability of concrete are discussed in greater detail in ACI 201.2R.

Free calcium hydroxide in hydrated cement paste will combine with carbon dioxide in the air to form calcium carbonate. Since calcium carbonate has a smaller volume than the calcium hydroxide, shrinkage will occur (commonly known as carbonation shrinkage). This shrinkage may result in significant surface crazing and may

be especially serious on freshly placed surfaces when improperly vented combustion heaters are used to keep concrete warm during the winter months.

With the exception of surface carbonation, very little can be done to protect or repair concrete that has been subjected to the types of chemical attack described above (ACI 201.2R).

**1.3.4 Weathering** — The weathering processes that can cause cracking include (1) freezing and thawing, (2) wetting and drying, and (3) heating and cooling. Cracking of concrete due to natural weathering is usually conspicuous and may give the impression that the concrete is on the verge of disintegration, even though the deterioration may not have progressed much below the surface.

Except in tropical regions, damage from freezing and thawing is the most common weather-related physical deterioration. Concrete may be damaged by freezing of water in the paste, in the aggregate, or in both.<sup>14</sup>

Damage in hardened cement paste from freezing is caused by the movement of water to freezing sites and by hydraulic pressure generated by the growth of ice crystals.<sup>14</sup>

Aggregate particles are surrounded by cement paste which prevents the rapid escape of water. When the aggregate particles are above a critical degree of saturation, the expansion of the absorbed water during freezing may crack the surrounding cement paste and/or damage the aggregate itself.<sup>15, 16</sup>

Concrete is best protected against freezing and thawing through the use of the lowest practical water-cement ratio and total water content, durable aggregate, and adequate air entrainment. Adequate curing prior to exposure to freezing conditions is also important. Allowing the structure to dry after curing will enhance its freeze-thaw durability.

Other weathering processes that may cause cracking in concrete are alternate wetting and drying, and heating and cooling. Both of these processes produce volume changes in concrete. If the volume changes are excessive, cracks may occur, as discussed in Sections 1.3.1 and 1.3.2.

**1.3.5 Corrosion of reinforcement** — Corrosion of a metal is an electro-chemical process that requires an oxidizing agent, moisture, and electron flow within the metal; a series of chemical reactions takes place on and adjacent to the surface of the metal. At points on the surface, known as anodes, metal atoms lose electrons, forming ions that go into solution. At other sites on the surface, known as cathodes, oxygen and water combine with free electrons to form hydroxyl ions ( $\text{OH}^-$ ). The hydroxyl ions move toward the anodes and combine with the metal ions to form hydrous metal oxides.

In the case of steel, iron oxide (rust) forms as a deposit at the anodes. On an individual piece of metal, there may be many anodes and cathodes, and these sites may be adjacent or widely spaced.

The key to protecting metal from corrosion is to stop or reverse the chemical reactions. This may be done by cutting off the supplies of oxygen or moisture or by



supplying excess electrons at the anodes to prevent the formation of the metal ions (cathodic protection).

Reinforcing steel usually does not corrode in concrete because a tightly adhering protective oxide coating forms in the highly alkaline environment. This is known as passive protection.

Reinforcing steel may corrode, however, if the alkalinity of the concrete is reduced through carbonation or the passivity of this steel is destroyed by aggressive ions (usually chlorides). Corrosion of the steel produces iron oxides and hydroxides, which have a volume much greater than the volume of the original metallic iron.<sup>17</sup> This increase in volume causes high radial bursting stresses around reinforcing bars and results in local radial cracks. These splitting cracks can propagate along the bar, resulting in the formation of longitudinal cracks (i.e., parallel to the bar) or spalling of the concrete. A broad crack may also form at a plane of bars parallel to a concrete surface, resulting in the delamination of the surface, a well-known problem in bridge decks.

Cracks provide easy access for oxygen, moisture, and chlorides, and thus, minor splitting cracks can create a condition in which corrosion continues and causes further cracking.

Cracks transverse to reinforcement usually do not cause continuing corrosion of the reinforcement if the concrete has low permeability. This is due to the fact that the exposed portion of a bar at a crack acts as an anode. At early ages, the wider the crack, the greater the corrosion, simply because a greater portion of the bar has lost its passive protection. However, for continued corrosion to occur, oxygen and moisture must be supplied to other portions of the same bar or bars that are electrically connected by direct contact or through hardware such as chair supports. If the combination of density and cover thickness is adequate to restrict the flow of oxygen and moisture, then the corrosion process is slowed or stopped.<sup>17</sup>

Corrosion can continue if a longitudinal crack forms parallel to the reinforcement, because passivity is lost at many locations, and oxygen and moisture are readily available along the full length of the bar.

Other causes of longitudinal cracking, such as high bond stresses, transverse tension (for example, along stirrups or along slabs with two-way tension), shrinkage, and settlement, can initiate corrosion.

For general concrete construction, the best protection against corrosion-induced splitting is the use of concrete with low permeability. Increased concrete cover over the reinforcing is effective in delaying the corrosion process and also in resisting the splitting and spalling caused by corrosion or transverse tension.<sup>18, 19</sup> In the case of large bars and thick covers, it may be necessary to add small transverse reinforcement (while maintaining the minimum cover requirements) to limit splitting and to reduce the surface crack width (ACI 345).

In very severe exposure conditions, additional protective measures may be required. A number of options

are available, such as coated reinforcement, sealers or overlays on the concrete, corrosion-inhibiting admixtures, and cathodic protection.<sup>20</sup> Any procedure that effectively prevents access of oxygen and moisture to the steel surface or reverses the electron flow at the anode will protect the steel.

**1.3.6 Poor construction practices** — A wide variety of poor construction practices can result in cracking in concrete structures. Foremost among these is the common practice of adding water to concrete to improve workability. Added water has the effect of reducing strength, increasing settlement, and increasing ultimate drying shrinkage. When accompanied by a higher cement content to help offset the decrease in strength, an increase in water content will also mean an increase in the temperature differential between the interior and exterior portions of the structure, resulting in increased thermal stresses and possible cracking.

Lack of curing will increase the degree of cracking within a concrete structure. The early termination of curing will allow for increased shrinkage at a time when the concrete has low strength. The lack of hydration of the cement, due to drying, will result not only in decreased long-term strength but also in the reduced durability of the structure.

Other construction problems that may cause cracking are inadequate form supports, inadequate consolidation, and placement of construction joints at points of high stress. Lack of support for forms or inadequate consolidation can result in settlement and cracking of the concrete before it has developed sufficient strength to support its own weight, while the improper location of construction joints can result in cracking at these planes of weakness.

Methods to prevent cracking due to these and other poor construction procedures are well known (see ACI 224R, ACI 302.1R, ACI 304, ACI 305R, ACI 308, ACI 309, ACI 345, and ACI 347), but require special attention by both the constructor and the owner's representative to insure their proper execution.

**1.3.7 Construction overloads** — Loads induced during construction can be far more severe than those experienced in service. Unfortunately, these conditions may occur at early ages when the concrete is most susceptible to damage and often result in permanent cracks.

Precast members, such as beams and panels, are most frequently subjected to this abuse, but cast-in-place concrete can also be affected. A common error occurs when precast members are not properly supported during transport and erection. The use of arbitrary or convenient lifting points may cause severe damage. Lifting eyes, pins, and other attachments should be detailed or approved by the designer. When lifting pins are impractical, access to the bottom of a member must be provided so that a strap may be used.

Operators of lifting devices must exercise caution and be aware that damage may be caused even when the proper lifting accessories are used. A large beam or panel lowered too fast, and stopped suddenly, carries



ificant momentum that translates into an impact that may be several times the dead weight of the member. Another common practice that should be avoided is prying up one corner of a panel to lift it off the support or "break it loose."

When considering the support of a member for shipment, the designer must be aware of loads that may be applied during transportation. Some examples that occur during shipment of large precast members via tractor and dolly are jumping curbs or tight highway corners, torsion due to differing roadway superelevations between the dolly and the tractor, and differential acceleration of the dolly and the tractor.

Pretensioned beams can present unique cracking problems at the time of stress release—usually when the beams are less than one day old. Multiple strands must be detensioned following a specific pattern, so as not to apply unacceptable eccentric loads on the member. If all the strands on one side of a beam are released while strands on the other side are still stressed, cracking will occur on the side with the fully stressed strands. These cracks are undesirable, but should close with the passage of time and the rebalancing of the strands.

In the case of a T-beam with a heavily reinforced flange and highly prestressed thin web, cracks may develop at the web-flange junction.

Another practice that can result in cracks near beam ends is tack welding embedded bearing plates to the concrete bed to hold them in place during concrete placement. The tack welds are broken only after the concrete strength is induced during stress transfer to the strands. Until then, the bottom of the beam is under tension while the rest of the beam is compressed. Cracks will form near the bearing plates if the welds are too strong.

Thermal shock can cause cracking of steam-cured concrete if it is treated improperly. The maximum rate of cooling frequently used is 70 F (21 C) per hour (ACI 517.2R).<sup>21-23</sup> When brittle aggregate is used and the concrete capacity is low, this rate should be decreased. Following this practice, thermally induced cracking seldom occurs. Temperature restrictions should apply to the entire beam, not just locations where temperatures are monitored. If the protective tarps commonly used to contain the heat are pulled back for access to the beam ends when cutting the strands, and if the ambient temperatures are low, thermal shock may occur. Heaters are seldom located in these critical areas.

Similar conditions and cracking potential exist with precast blocks, curbs, and window panels when a rapid surface temperature drop occurs.

As noted by some researchers (ACI 517.2R)<sup>24-28</sup> and the Energy Committee<sup>29-31</sup> that rapid cooling may cause cracking only in the surface layers of very thick units and that rapid cooling is not detrimental to the strength or durability of standard precast products.<sup>29</sup> One exception is the severe cracking observed in pretensioned beams subjected to cooling prior to detensioning. For this reason, pretensioned members should be detensioned immediately after steam-curing has been discontinued.<sup>29</sup>

Cast-in-place concrete can be unknowingly subjected to construction loads in cold climates when heaters are used to provide an elevated working temperature within a structure. Typically, tarps are used to cover windows and door openings, and high volume heaters are operated inside the enclosed area. If the heaters are located near exterior concrete members, especially thin walls, an unacceptably high thermal gradient can result within the members. The interior of the wall will expand in relation to the exterior. Heaters should be kept away from the exterior walls to minimize this effect. Good practice also requires that this be done to avoid localized drying shrinkage and carbonation cracking.

Storage of materials and the operation of equipment can easily result in loading conditions during construction far more severe than any load for which the structure was designed. Unfortunately, there is seldom tight control over these loads. Damage from unintentional construction overloads can be prevented only if designers provide information on load limitations for the structure and if construction personnel heed these limitations.

**1.3.8 Errors in design and detailing** — The effects of improper design and/or detailing range from poor appearance to lack of serviceability to catastrophic failure. These problems can be minimized only by a thorough understanding of structural behavior (meant here in the broadest sense). Unfortunately, they often occur because of insufficient attention on the part of the designer.

Errors in design and detailing that may result in unacceptable cracking include use of poorly detailed reentrant corners in walls, precast members and slabs, improper selection and/or detailing of reinforcement, restraint of members subjected to volume changes caused by variations in temperature and moisture, lack of adequate contraction joints, and improper design of foundations, resulting in differential movement within the structure. Examples of these problems are presented in References 2 and 32.

Reentrant corners provide a location for the concentration of stress and, therefore, are prime locations for the initiation of cracks. Whether the high stresses result from volume changes, in-plane loads, or bending, the designer must recognize that stresses are always high near reentrant corners. Well-known examples are window and door openings in concrete walls and dapped-end beams, as shown in Fig. 1.4 and 1.5. Additional properly anchored diagonal reinforcement is required to keep the inevitable cracks narrow and prevent them from propagating.

The use of an inadequate amount of reinforcing may result in excessive cracking. A typical mistake is to lightly reinforce a member because it is a "nonstructural member." However, the member in question (such as a wall) may be tied to the rest of the structure in such a manner that it is required to carry a major portion of the load once the structure begins to deform. The "nonstructural element" then begins to carry loads in proportion to its stiffness. Since this



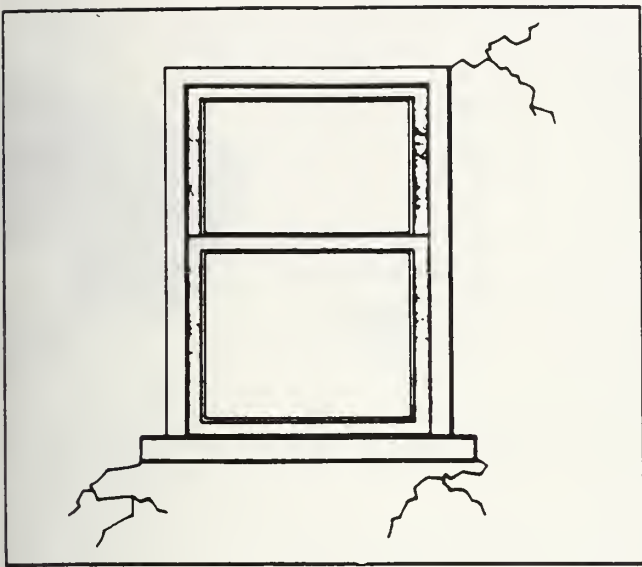

Fig. 1.4—Typical crack patterns at reentrant corners (Reference 2)

member is not detailed to act structurally, unsightly cracking may result even though the safety of the structure is not in question.

The restraint of members subjected to volume changes results frequently in cracks. Stresses that can occur in concrete due to restrained creep, temperature differentials, and drying shrinkage can be many times the stresses that occur due to loading. A slab, wall, or a beam restrained against shortening, even if prestressed, can easily develop tensile stresses sufficient to cause cracking. Properly designed walls will have contraction joints spaced from one to three times the wall height. Beams will be allowed to move. Cast-in-place post-tensioned construction that does not permit shortening of the prestressed member is susceptible to cracking in both the member and the supporting structure.<sup>33</sup> The problem with restraint of structural members is especially serious in pretensioned and precast members that may be welded to the supports at both ends. When combined with other problem details (such as reentrant corners), catastrophic results may be obtained.<sup>32, 34</sup>

Improper foundation design may result in excessive differential movement within a structure. If the differential movement is relatively small, the cracking problems may be only visual in nature. However, if there is a major differential settlement, the structure may not be able to redistribute the loads rapidly enough, and a failure may occur. One of the advantages of reinforced concrete is that, if the movement takes place over a long enough period of time, creep will allow at least some load redistribution to occur.

The importance of proper design and detailing will depend on the particular structure and loading involved. Special care must be taken in the design and detailing of structures in which cracking may cause a major serviceability problem. These structures also require continuous inspection during all phases of construction to supplement the careful design and detailing.

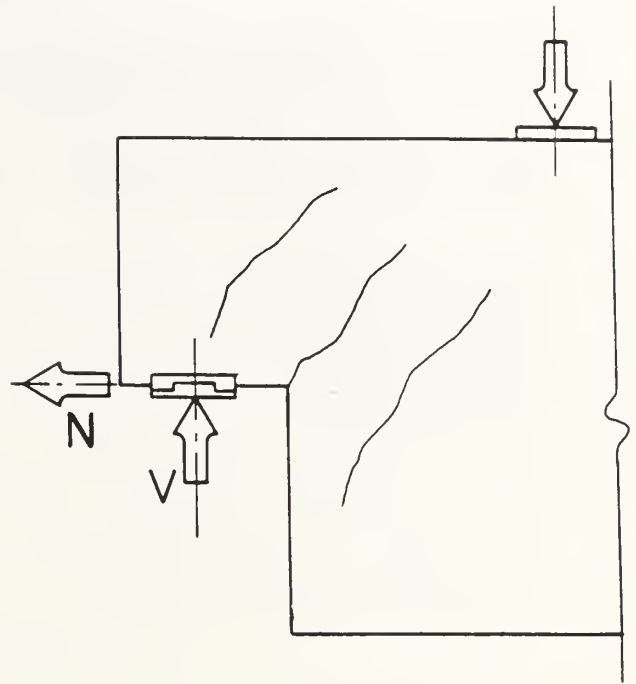

Fig. 1.5 — Typical cracking pattern of dapped-end at service load\*

A pertinent example is the category of sanitary structures, for which ACI Committee 350 has separate design requirements (ACI 350R) specifically aimed at providing for well-distributed cracks of minimum width. However, even the recommendations of Committee 350 will not insure proper crack control unless the properties, loadings, environment, and characteristics of the specific structure are taken into account.

**1.3.9 Externally applied loads** — It is well known that load-induced tensile stresses result in cracks in concrete members. This point is readily acknowledged and accepted in concrete design. Current design procedures (ACI 318 and AASHTO Standard Specifications for Highway Bridges) use reinforcing steel, not only to carry the tensile forces, but to obtain both an adequate crack distribution and a reasonable limit on crack width.

Because of the complexity of the analysis, the development of load-induced crack control provisions has historically depended on the analysis of experimental work. In particular, crack patterns and crack widths have been investigated in detail for cracks associated with tensile and flexural stresses. However, shear and torsion may also cause significant cracking.

Current knowledge of flexural members provides the basis for the following general conclusions about the variables that control cracking: Crack width increases with increasing steel stress, cover thickness, and area of concrete surrounding each reinforcing bar. Of these, steel stress is the most important variable. The bar diameter is not a major consideration. The width of a

\*From Alan H. Mattock and Timothy C. Chan, "Design and Behavior of Dapped-End Beams," *Journal, Prestressed Concrete Institute*, V. 24, No. 6, Nov.-Dec. 1979, pp. 28-45.







Fig. 1—Comparator for measuring crack widths (Courtesy of Edmund Scientific Co.)

Crack width increases with an increasing strain gradient between the steel and the tension face of the

equation considered to best predict the most probable maximum surface crack width in bending was developed by Gergely and Lutz.<sup>35</sup> A simplified version of this equation follows.

$$w = 0.076\beta f_r \sqrt{d_c A} \times 10^{-3} \quad (1.1)$$

where  $w$  = most probable maximum crack width, in.;  $\beta$  = ratio of distance between neutral axis and tension face to distance between neutral axis and centroid of reinforcing steel ( $\approx 1.20$  in beams);  $f_r$  = reinforcing steel stress, ksi;  $d_c$  = thickness of cover from tension face to center of bar closest thereto, in.; and  $A$  = area of concrete symmetric with reinforcing steel divided by number of bars, in.<sup>2</sup>.

A modification of this equation is used in ACI 318, which limits crack widths to 0.016 in. (0.41 mm) for interior exposure and 0.013 in. (0.33 mm) for exterior exposure. However, considering the information presented in Section 1.3.5 which indicates no connection between surface crack width for cracks transverse to the direction of the reinforcement and the corrosion of reinforcing, these limits do not appear to be justified on the basis of corrosion prevention.

There have been a number of equations developed for predicting crack widths in prestressed concrete members (ACI 244R), without any one method achieving general acceptance.

The maximum crack width in tension members is often greater than predicted by the expression for flexural cracks.<sup>36, 37</sup> Absence of a strain gradient and compression in tension members is the probable reason for the larger crack widths.

On the basis of limited data, the following expression has been suggested to estimate the maximum tensile crack width (ACI 224R).

$$w = 0.10 f_r \sqrt{d_c A} \times 10^{-3} \quad (1.2)$$

Both flexural and tensile crack widths can be expected to increase with time for members subjected to either sustained or repetitive loading. Although a large degree of scatter is evident in the available data, a doubling of

crack width with time can be expected.<sup>38-42</sup> Under most conditions, the spacing of cracks does not change with time at constant levels of stress. Exceptions occur at low loads or in beams with high percentages of reinforcement, in which case the total number and width of cracks increase substantially after the loading has begun.<sup>39, 42</sup>

Although work remains to be done, the basic principles of crack control for load-induced cracks are well understood. Well-distributed reinforcing offers the best protection against undesirable cracking. A reduced steel stress, obtained through the use of a larger amount of steel, will also reduce the amount of cracking. While a reduced cover will reduce the surface crack width, designers must keep in mind, as pointed out in Section 1.3.5, that cracks (and therefore, crack widths) perpendicular to reinforcing steel do not have a major effect on the corrosion of that steel, while a reduction in cover will be detrimental to the corrosion protection of the reinforcing.

## CHAPTER 2 — EVALUATION OF CRACKING

### 2.1 — Introduction

Before proceeding with repairs, an evaluation should be made to determine the location and extent of cracking, the causes of cracking, and the need for repair. Calculations can be made to determine stresses due to applied loads. Drawings, specifications, and construction and maintenance records should be reviewed. Discrepancies with field data should be noted.

The causes of cracks are discussed in Chapter 1. A detailed evaluation of observed cracking can determine which of these causes applies in a particular situation.

Cracks need to be repaired if they reduce the strength, stiffness, or durability of the structure to an unacceptable level. Repairs may be required to improve the appearance of the concrete surface. Cracks also require repair if the function of the structure is seriously impaired. In some cases, such as cracking in water-retaining structures, the function of the structure will dictate the need for repair, even if strength, stiffness, or appearance are not significantly affected. Cracks in pavements and slabs-on-grade may require repair to prevent edge spalls, migration of water to the subgrade, or transmit loads.

### 2.2 — Determination of location and extent of cracking

Location and extent of cracking, as well as information on the general condition of concrete in a structure, can be determined by visual inspection, nondestructive testing, and tests of cores taken from the structure. Information can also be obtained from drawings, and construction and maintenance records.

**2.2.1 Visual inspection** — The location and width of cracks should be noted on a sketch of the structure. A grid marked on the surface of the structure can be useful to accurately locate cracks on the sketch.

Crack widths can be measured with an accuracy of about 0.001 in. (0.025 mm) using a crack comparator,



which is a small hand-held microscope with a scale on the lens closest to the surface being viewed (Fig. 2.1). Locations of observed spalling, exposed reinforcement, surface deterioration, and rust staining should be noted on the sketch.

Crack movement can be monitored with mechanical movement indicators of the types shown in Fig. 2.2. The indicator, or crack monitor, in Fig. 2.2(a) gives a direct reading of crack displacement and rotation. The indicator in Fig. 2.2(b)<sup>43</sup> amplifies the crack movement (in this case, 50 times) and indicates the maximum range of movement occurring during the measurement period. Mechanical indicators have the advantage that they do not require moisture protection. If more detailed time histories are desired, a wide range of transducers (most notably linear variable differential transformers or LVDTs) and data acquisition systems (ranging from strip chart recorders to computer based systems) are available.

Sketches can be supplemented by photographs showing the condition of the structure. Guidance for making a condition survey of concrete in service is given in ACI 201.1R.

**2.2.2 Nondestructive testing** — Nondestructive tests can be made to determine the presence of internal cracks and voids and the depth of penetration of cracks visible at the surface.

Tapping the surface with a hammer or using a chain drag are simple techniques to identify planar cracking near the surface. A hollow sound indicates a separation or crack below the surface.

The presence of reinforcement can be determined using a pachometer (Fig. 2.3). A number of pachometers are available that range in capability from merely indicating the presence of steel to those that may be calibrated to give either the depth or the size (provided that the other is known) of the reinforcing.<sup>44</sup> In some cases, however, it may be necessary to remove the concrete cover to identify the bar sizes, especially in areas of congested reinforcement.

If corrosion is a suspected cause of cracking, the easiest approach entails the removal of a portion of the concrete to directly observe the steel. Corrosion potential can be detected by electrical potential measurements using a suitable reference half cell. The most commonly used is a copper-copper sulfate half cell (ASTM C 876 and Reference 45). Use of a half cell also requires access to a portion of the reinforcing steel.

With properly trained personnel and careful evaluation, it may be possible to detect cracking using ultrasonic nondestructive test equipment (ASTM C 597). The most common technique is through-transmission testing using a sonoscope or other commercially available equipment.<sup>46, 47</sup> A mechanical pulse is transmitted to one face of the concrete member and received at the opposite face, as shown in Fig. 2.4. When access is not available to opposite faces, transducers may be located on the same face [Fig. 2.4(a)]. The time taken for the pulse to pass through the member is measured electronically. If the distance between the transmitting and

receiving transducers is known, the pulse velocity can be calculated.

A significant change in measured pulse velocity can occur if an internal discontinuity results in an increase in path length for the signal. Generally, the higher the pulse velocity, the higher the quality of the concrete.

Internal discontinuities can also be detected by the attenuation of the signal strength if the signal is displayed on an oscilloscope [Fig. 2.4(b)]. However, some equipment provides only a digital readout of the pulse travel time, with no oscilloscope display. If no signal arrives at the receiving transducer, a significant internal discontinuity, such as a crack or void, is indicated. An indication of the extent of the discontinuity can be obtained by taking readings at a series of positions on the member.

Ultrasonic equipment should be operated by a trained technician, and the results should be evaluated cautiously by an experienced engineer or technician, because moisture, reinforcing steel, and embedded items may affect the results. For example, with fully saturated cracks, ultrasonic testing will generally be ineffective. In some cases, it is difficult to discern between a group of close cracks and a single large crack.

A possible alternative to through-transmission testing is the pulse-echo method,<sup>48\*</sup> which is still in the developmental stage. A major advantage of this technique is that access to only one face of the member is required. A mechanical pulse is generated by impact on one face of the member. The signal passes through the member, reflects from the back face of the member, and is received by a transducer at the front face. For a solid member, the oscilloscope screen display consists of a signal corresponding to the original impact and a signal for the reflected pulse, as shown in Fig. 2.5. Intermediate signals indicate the presence of internal discontinuities. The pulse velocity can also be determined if the path length is known.

Radiography can be used to detect internal discontinuities. Both x-ray and gamma-ray equipment are available.<sup>46</sup> The procedures are best suited for detecting crack planes parallel to the direction of radiation; it is difficult to discern crack planes perpendicular to the radiation. Gamma-ray equipment is less expensive and relatively portable compared to x-ray equipment and therefore appears to be more suitable for field testing.

An important use of nondestructive testing is finding those portions of the structure that require a more detailed investigation, which may include core tests.

**2.2.3 Tests on concrete cores** — Significant information can be obtained from cores taken from selected locations within the structure. Cores and core holes afford the opportunity to accurately measure the width and depth of cracks. In addition, an indication of concrete quality can be obtained from compressive strength

\*Scanlon, Andrew; Salse, Eduardo A. B.; Corley, W. Gene; and Muenow, Richard A., "Evaluation of Cracking Using Ultrasonic Test Methods," presented at the technical session on structural repair of cracks, ACI Fall Convention, Detroit, Sept. 1980.



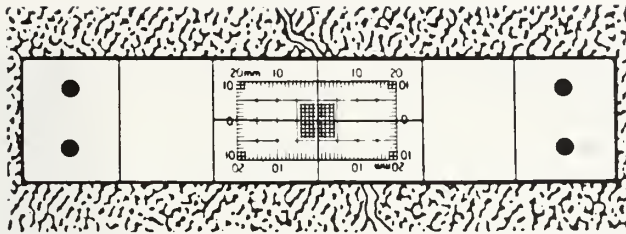

Newly Mounted Monitor

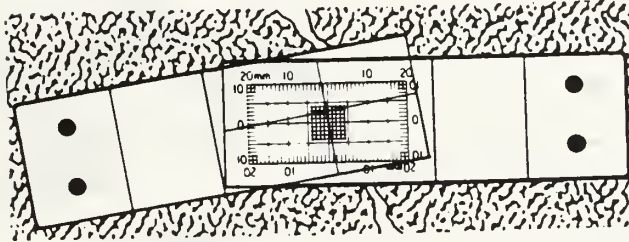

Monitor After Crack Movement

(a)—Crack monitor (courtesy of Avongard)

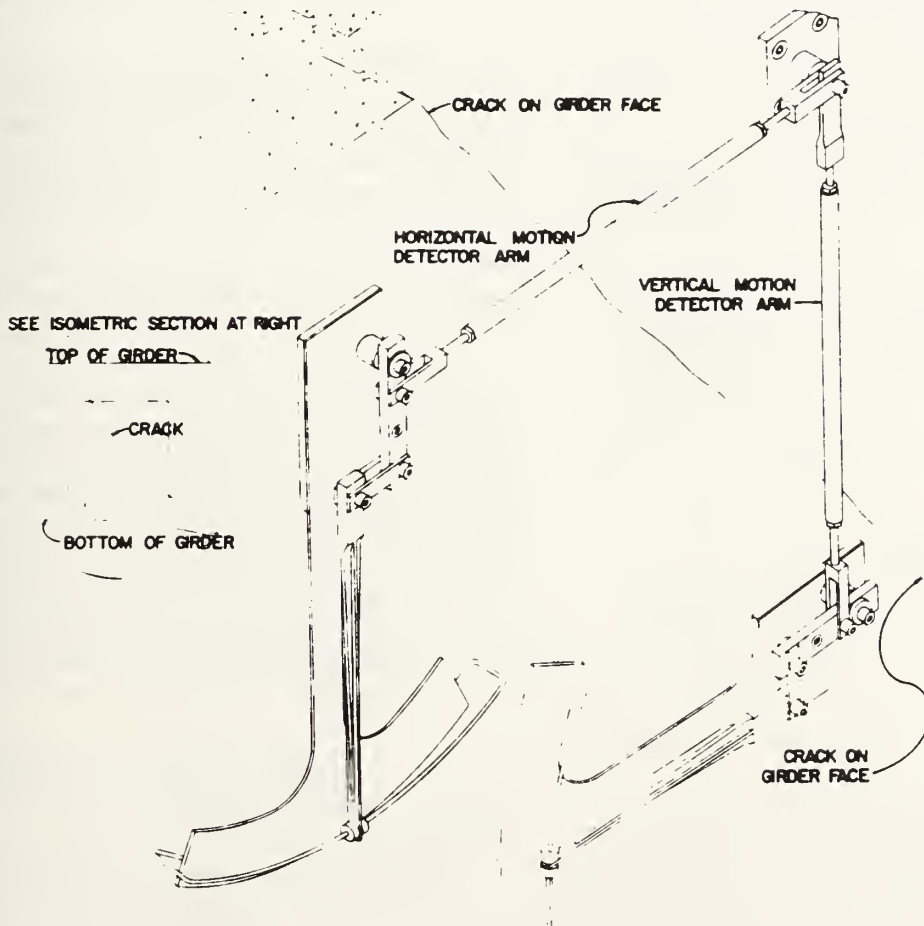

(b)—Crack movement indicator (Reference 43)

Fig. 2.2





Fig. 2.3—Pachometer (reinforcing bar locator) (courtesy of James Instruments)

tests. However, cores that contain cracks should not be used to determine concrete strength.

Core material and crack surfaces can be examined petrographically to determine the presence of alkali-silica reaction products or other deleterious substances (ACI 201.2R).

Chemical tests for the presence of excessive chlorides may indicate the potential for corrosion of embedded reinforcement.

**2.2.4 Review of drawings and construction data** — Available design and reinforcement placing drawings should be examined to determine if and where observed cracking can be attributed to inadequate detailing of reinforcement. Calculations can indicate whether the reinforcement provided is adequate for the applied loads. Restraint conditions and the presence of contraction, expansion, and construction joints should be considered in calculating the induced tensile stresses. A comparison should be made between the design loads and the actual loads acting on the structure.

### 2.3 — Selection of repair procedures

Based on the careful evaluation of the extent and cause of cracking, procedures can be selected to accomplish one or more of the following objectives:

1. Restore or increase strength;
2. Restore or increase stiffness;
3. Improve functional performance;
4. Provide watertightness;
5. Improve appearance of the concrete surface;
6. Improve durability; and/or
7. Prevent access of corrosive materials to reinforcement.

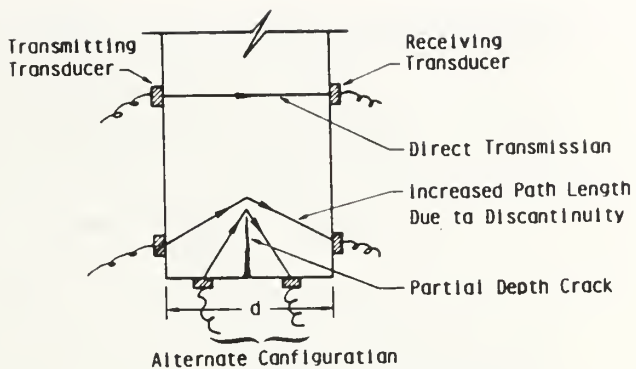

a) Pulse transmitted through member

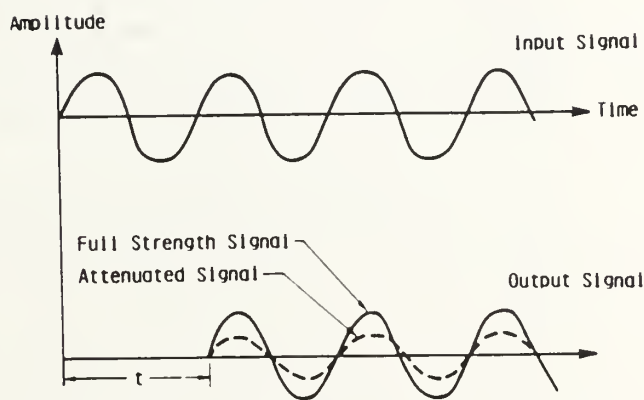

$t$  = Time delay between Transmitting and Receiving signals  
Pulse velocity =  $d/t$

b) Oscilloscope Signal

Fig. 2.4—Ultrasonic testing, through-transmission technique

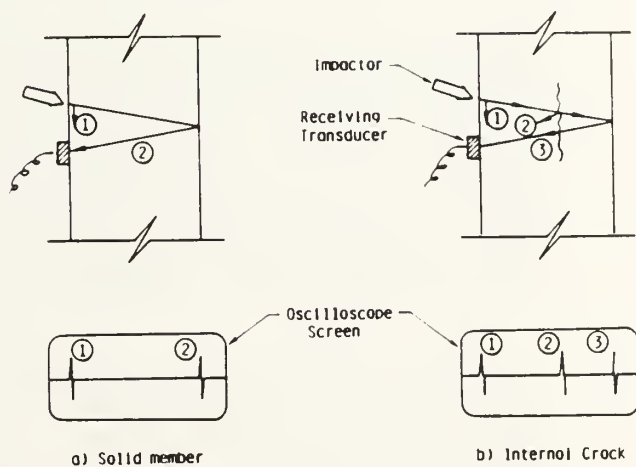

Fig. 2.5—Ultrasonic testing, pulse echo technique

Depending on the nature of the damage, one or more repair methods may be selected. For example, tensile strength can be restored across a crack by injecting it with epoxy. However, it may be necessary to provide additional strength by adding reinforcement or using post-tensioning. Epoxy injection alone can be used to restore flexural stiffness if further cracking is not anticipated (ACI 503R).

Cracks causing leaks in water-retaining structures should be repaired unless the leakage is considered minor or there is an indication that the crack is being





by autogenous healing (see Section 3.13). Reto stop leaks may be complicated by a need to the repairs while the structures are in service and liquid.

en cracks result in an unacceptable appearance, an be repaired. However, the crack location will e visible, and it is likely that some form of coat- the entire surface may be required.

minimize future deterioration due to the corro- of reinforcement, cracks exposed to a moist envi- nent should be sealed.

key methods of crack repair available to accom- the objectives outlined are described in Chapter 3.

## CHAPTER 3 — METHODS OF CRACK REPAIR

### 1. Introduction

Following the evaluation of the cracked structure and determination of the cause of the cracking, a suitable repair procedure can be selected. Successful repair procedures take into account the cause of the cracking. For example, if the cracking was primarily due to shrinkage, then it is likely that after a period of time the cracks will stabilize. On the other hand, if the cracks are due to a continuing foundation settlement, the repair will be of no use until the settlement problem is corrected.

This chapter provides a survey of crack repair methods, including a summary of the characteristics of the methods that may be repaired with each procedure, the types of structures that have been repaired, and a summary of the procedures that are used. Readers are also referred to ACI 546.1R and Reference 49, which specifically address the subject of concrete repair.

### 2. Epoxy injection

Cracks as narrow as 0.002 in. (0.05 mm) can be sealed by the injection of epoxy. The technique generally consists of drilling holes at close intervals along the cracks, in some cases installing entry ports, and injecting the epoxy under pressure. For massive structures an alternative procedure consists of drilling a series of holes [usually  $\frac{7}{8}$  in. (22 mm) in diameter] that intercepts the crack at a number of locations. Typical holes are spaced at 5 ft (1.5 m) intervals.

Epoxy injection has been successfully used in the repair of cracks in buildings, bridges, dams, and other types of concrete structures (ACI 503R). However, unless the crack is dormant (or the cause of cracking is removed, thereby making the crack dormant), it will probably recur, possibly somewhere else in the structure. If the cracks are active and it is desired to seal them while allowing continued movement at that location, it is necessary to use a sealant or other material that allows that crack to function as a joint. ACI 504R describes practices for sealing joints, including joint types, available materials, and methods of application.

With the exception of certain specialized epoxies, this technique is not applicable if the cracks are actively leaking and cannot be dried out. While moist cracks

can be injected, contaminants in the crack (including water) will reduce the effectiveness of the epoxy to structurally repair the crack.

Epoxy injection requires a high degree of skill for satisfactory execution, and application of the technique may be limited by the ambient temperature (ACI 503R). The general procedures involved in epoxy injection are as follows (ACI 503R):

1. *Clean the cracks.* The first step is to clean the cracks that have been contaminated. Oil, grease, dirt, or fine particles of concrete prevent epoxy penetration and bonding. Preferably, contamination should be removed by flushing with water or other specially effective solvent. The solvent is then blown out using compressed air or adequate time is provided for air drying.

2. *Seal the surfaces.* Surface cracks should be sealed to keep the epoxy from leaking out before it has gelled. Where the crack face cannot be reached, but where there is backfill, or where a slab-on-grade is being repaired, the backfill material or subbase material is often an adequate seal. A surface can be sealed by brushing an epoxy along the surface of the crack and allowing it to harden. If extremely high injection pressures are needed, the crack should be cut out to a depth of  $\frac{1}{2}$  in. (13 mm) and width of about  $\frac{3}{4}$  in. (19 mm) in a V-shape, filled with an epoxy, and struck off flush with the surface. If a permanent glossy appearance along the crack is objectionable and if high injection pressure is not required, a strippable plastic may be applied along the crack. When the job is completed, the dry filler can be stripped away to expose the gloss-free surface.

3. *Install the entry ports.* Three methods are in general use:

a. *Drilled holes-fittings inserted.* Historically, this method was the first to be used, and is often used in conjunction with V-grooving of the cracks. The method entails drilling a hole into the crack, approximately  $\frac{3}{4}$  in. (19 mm) in diameter and  $\frac{1}{2}$  to 1 in. (13 to 25 mm) below the apex of the V-grooved section, into which a fitting such as a pipe nipple or tire valve stem is bonded with an epoxy adhesive. A vacuum chuck and bit are useful in preventing the cracks from being plugged with drilling dust.

b. *Bonded flush fitting.* When the cracks are not V-grooved, a method frequently used to provide an entry port is to bond a fitting flush with the concrete face over the crack. This flush fitting has a hat-like cross section with an opening at the top for the adhesive to enter.

c. *Interruption in seal.* Another system of providing entry is to omit the seal from a portion of the crack. This method can be used when special gasket devices are available that cover the unsealed portion of the crack and allow injection of the adhesive directly into the crack without leaking.

4. *Mix the epoxy.* This is done either by batch or continuous methods. In batch mixing, the adhesive components are premixed according to the manufacturer's instructions, usually with the use of a mechanical stirrer, like a paint mixing paddle. Care must be



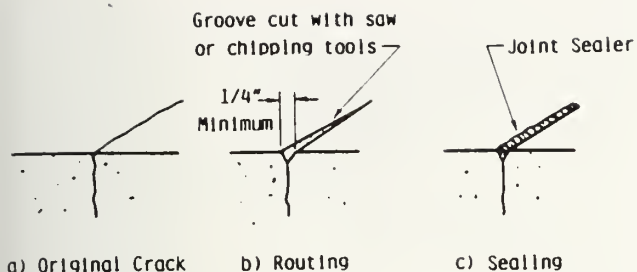

Fig. 3.1—Repair of crack by routing and sealing (Reference 51)

taken to mix only the amount of adhesive that can be used prior to commencement of gelling of the material. When the adhesive material begins to gel, its flow characteristics begin to change, and pressure injection becomes more and more difficult. In the continuous mixing system, the two liquid adhesive components pass through metering and driving pumps prior to passing through an automatic mixing head. The continuous mixing system allows the use of fast setting adhesives that have a short working life.

5. *Inject the epoxy.* Hydraulic pumps, paint pressure pots, or air-actuated caulking guns can be used. The pressure used for injection must be carefully selected. Increased pressure often does little to accelerate the rate of injection. In fact, the use of excessive pressure can propagate the existing cracks, causing additional damage.

If the crack is vertical, the injection process should begin by pumping epoxy into the entry port at the lowest elevation until the epoxy level reaches the entry port above. The lower injection port is then capped, and the process is repeated at successively higher ports until the crack has been completely filled and all ports have been capped.

For horizontal cracks, the injection should proceed from one end of the crack to the other in the same manner. The crack is full if the pressure can be maintained. If the pressure cannot be maintained, the epoxy is still flowing into unfilled portions or leaking out of the crack.

6. *Remove the surface seal.* After the injected epoxy has cured, the surface seal should be removed by grinding or other means, as appropriate. Fittings and holes at entry ports should be painted with an epoxy patching compound.

In the specific case of delaminated bridge decks, epoxy injection can be an effective intermediate term repair procedure.<sup>50</sup> In this case, the first, second, and sixth steps are omitted. The process is terminated at a specific location when epoxy exits from the crack at some distance from the injection ports. This procedure does not arrest ongoing corrosion.

### 3.3 — Routing and sealing

Routing and sealing can be used on cracks that are dormant and of no structural significance. This method involves enlarging the crack along its exposed face and filling and sealing it with a suitable joint sealant (Fig.

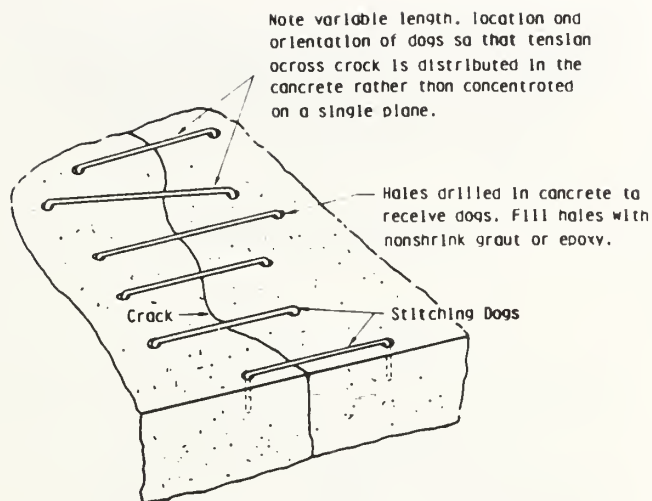

Fig. 3.2—Repair of crack by stitching (Reference 51)

3.1). The routing operation may be omitted, but at some sacrifice in the permanence of the repair.

This is the simplest and most common technique for crack repair. It can be executed with relatively untrained labor (compared to epoxy injection) and is applicable for sealing both fine pattern cracks and larger isolated defects. The method will not be effective on an active crack (for sealing of active cracks, see Section 3.7). Routing and sealing are not applicable for sealing cracks subject to a pronounced hydrostatic pressure, except when sealing the pressure face, in which case some reduction in the flow can be obtained.

The routing operation consists of preparing a groove at the surface that is sufficiently large to receive the sealant, using a concrete saw, hand tools, or pneumatic tools. A minimum surface width of  $\frac{1}{4}$  in. (6 mm) is desirable. Repairing narrower grooves is difficult. The surfaces of the routed joint should be cleaned with an air jet and permitted to dry before placing the sealant.

The purpose of the sealant is to prevent water from reaching the reinforcing steel, hydrostatic pressure from developing within the joint, staining the concrete surface, or causing moisture problems on the far side of the member.

The sealant may be any of several materials, depending on how tight or permanent a seal is desired. Epoxy compounds are often used. Hot-poured joint sealants work very well when thorough watertightness of the joint is not required and appearance is not important. Urethanes, which remain flexible through large temperature variations, have been used successfully in cracks up to  $\frac{3}{4}$  in. (19 mm) in width and of considerable depth. There are many commercial products, and the manufacturers should be consulted as to the type and grade most applicable for the specific purpose and condition of exposure. The method of placing depends on the material to be used and should follow the techniques recommended in ACI 504R.

### 3.4 — Stitching

This method involves drilling holes on both sides of the crack and grouting in stitching dogs (U-shaped



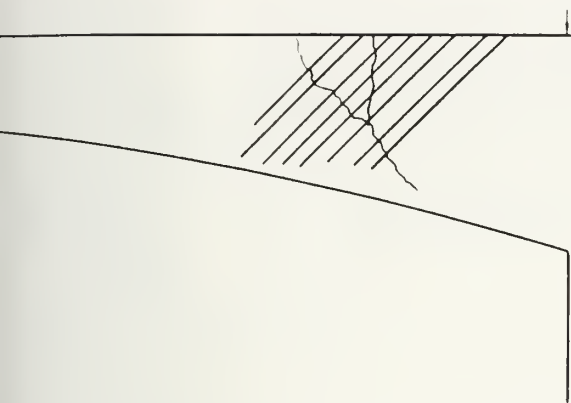

3.3—Reinforcing bar orientation used to effect the re-  
(Reference 43)

units with short legs) that span the crack (Fig. 51). Stitching may be used when tensile strength must be re-established across major cracks. Stitching a crack serves to stiffen the structure, and the stiffening may attenuate the overall structural restraint, causing the concrete to crack elsewhere. Therefore, it may be necessary to strengthen the adjacent section using external reinforcement embedded in a suitable overlay.

The stitching procedure consists of drilling holes on both sides of the crack, cleaning the holes, and anchoring the legs of the dogs in the holes, with either a non-shrink grout or an epoxy resin-based bonding system. The stitching dogs should be variable in length and orientation or both, and they should be located so that the load transmitted across the crack is not applied to a single plane within the section but is spread over an area.

The spacing of the stitching dogs should be reduced at the ends of cracks. In addition, consideration should be given to drilling a hole at each end of the crack to blunt and relieve the concentration of stress.

Where possible, stitch both sides of the concrete section so that further movement of the structure will not occur or bend the dogs. In bending members, it is possible to stitch one side of the crack only. This should be done on the tension face, where movement is occurring. If the member is in a state of axial tension, then the dogs must be placed symmetrically, even if excavation or demolition is required to gain access to opposite sides of the section.

Stitching will not close a crack but can prevent it from propagating further. Where there is a water problem, the crack should be made watertight as well as sealed to protect the dogs from corrosion. This repair should be completed before stitching begins. An exception should be made in the case of active cracks, where the structure must be stabilized before being made watertight, because movement at the crack may break the sealant material within the crack.

The dogs are relatively thin and long, and cannot resist much compressive force. Accordingly, if there is a tendency for the crack to close as well as to open, the concrete must be stiffened and strengthened, for example, by encasement in an overlay.

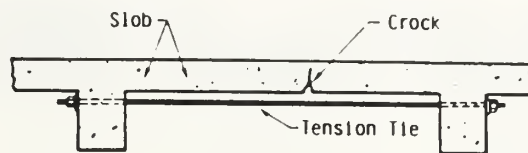

a) To Correct Cracking of Slob

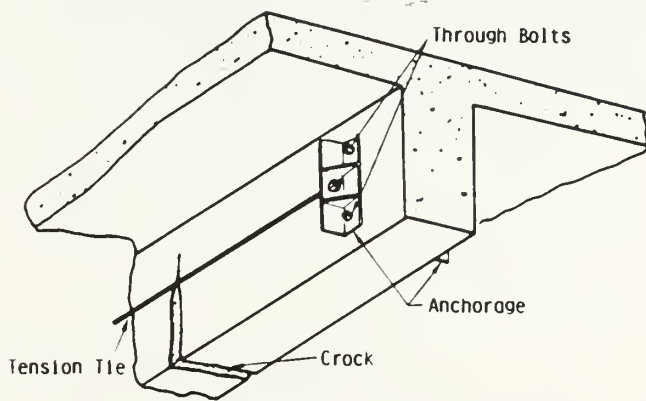

b) To Correct Cracking of Beam

Fig. 3.4—Examples of external prestressing (Reference 51)

### 3.5 — Additional reinforcement

**3.5.1 Conventional reinforcement** — Cracked reinforced concrete bridge girders have been successfully repaired using epoxy injection and reinforcing bar insertion.<sup>43, 52, 53</sup> This technique consists of sealing the crack, drilling holes [ $\frac{3}{4}$  in. (19 mm) in diameter] at 45 deg to the deck surface and crossing the crack plane at approximately 90 deg (Fig. 3.3), filling the hole and crack plane with epoxy pumped under low pressure [50 to 80 psi (342 to 548 kPa)], and placing a reinforcing bar into the drilled hole. Typically No. 4 or 5 (13 or 16 mm) bars are used, extending at least 18 in. (0.46 m) on each side of the crack. The epoxy bonds the bar to the walls of the hole, fills the crack plane, bonds the cracked concrete surfaces back together in one monolithic form, and thus reinforces the section.

A temporary elastic exterior crack sealant is required for a successful repair. Gel-type epoxy crack sealants work very well within their elastic limits. Silicone rubber gap sealants work well and are especially attractive in cold weather or when time is short. The sealant should be applied in a uniform layer approximately  $\frac{1}{16}$  to  $\frac{1}{8}$  in. (1.6 to 2.4 mm) thick and should span the crack by at least  $\frac{3}{4}$  in. (19 mm) on each side.

The epoxy used to rebond the crack should have a very low viscosity and a high modulus of elasticity. It should be capable of bonding to concrete in the presence of moisture, and it should be 100 percent reactive.

The reinforcing bars can be spaced to suit the needs of the repair. They can be placed in any desired pat-



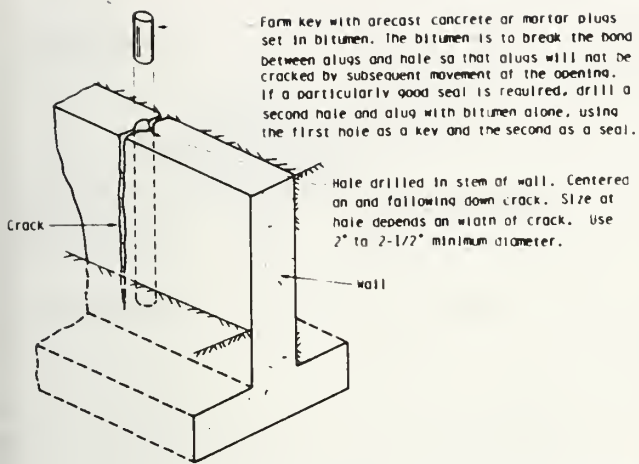

Fig. 3.5—Repair of crack of drilling and plugging (Reference 51)

tern, depending on the design criteria and the location of the in-place reinforcement.

**3.5.2 Prestressing steel** — Post-tensioning is often the desirable solution when a major portion of a member must be strengthened or when the cracks that have formed must be closed (Fig. 3.4). This technique uses prestressing strands or bars to apply a compressive force. Adequate anchorage must be provided for the prestressing steel, and care is needed so that the problem will not merely migrate to another part of the structure. The effects of the tensioning force (including eccentricity) on the stress within the structure should be carefully analyzed. For indeterminate structures post-tensioning using this procedure, the effects of secondary moments and induced reactions should be considered.<sup>54, 55</sup>

### 3.6 — Drilling and plugging

Drilling and plugging a crack consists of drilling down the length of the crack and grouting it to form a key (Fig. 3.5).

This technique is only applicable when cracks run in reasonably straight lines and are accessible at one end. This method is most often used to repair vertical cracks in retaining walls.

A hole [typically 2 to 3 in. (50 to 75 mm) in diameter] should be drilled, centered on and following the crack. The hole must be large enough to intersect the crack along its full length and provide enough repair material to structurally take the loads exerted on the key. The drilled hole should then be cleaned, made tight, and filled with grout. The grout key prevents transverse movement of the sections of concrete adjacent to the crack. The key will also reduce heavy leakage through the crack and loss of soil from behind a leaking wall.

If water tightness is essential and structural load transfer is not, the drilled hole should be filled with a resilient material of low modulus in lieu of grout. If the keying effect is essential, the resilient material can be placed in a second hole, the first being grouted.

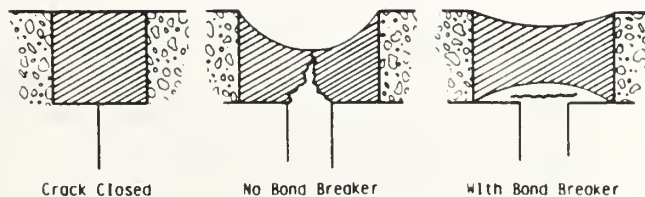

Fig. 3.6—Effect of bond breaker

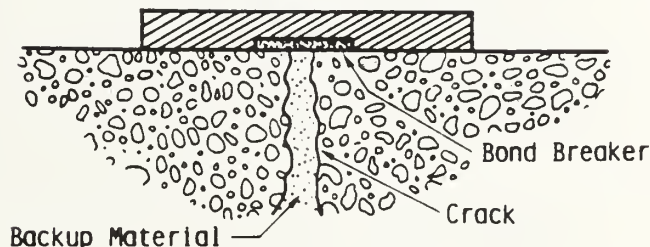

Fig. 3.7—Repair of crack using flexible surface seal

### 3.7 — Flexible sealing

Active cracks can be routed out; cleaned by sand-blast, air-water jet, or both; and filled with a suitable field-molded flexible sealant. As nearly as is practical, the sealant reservoir (slot) formed by routing should comply with the requirements for width and shape factor of a joint having equivalent movement.

The selection of a suitable sealant and installation method should follow those for equivalent joints (ACI 504R).

A bond breaker should be provided at the bottom of the slot to allow the sealant to change shape without a concentration of stress on the bottom (Fig. 3.6). The bond breaker may be a polyethylene strip, pressure sensitive tape, or other material which will not bond to the sealant before or during cure.

Narrow cracks subject to movement, where esthetics are not important, may be sealed with a flexible surface seal (Fig. 3.7).

By using a bond breaker over the crack, a flexible joint sealant may be troweled over the bond breaker providing an adequate bonding area. This is a very economical procedure and may be used on the interior of a tank, roofs, or other areas not subject to traffic or mechanical abuse.

### 3.8 — Grouting

**3.8.1 Portland cement grouting** — Wide cracks, particularly in gravity dams and thick concrete walls, may be repaired by filling with portland cement grout. The procedure consists of cleaning the concrete along the crack; installing built-up seats (grout nipples) at intervals astride the crack (to provide a pressure tight contact with the injection apparatus); sealing the crack between the seats with a cement paint, sealant, or grout; flushing the crack to clean it and test the seal; and then grouting the whole area. Grout mixtures may contain cement and water or cement plus sand and water, de-





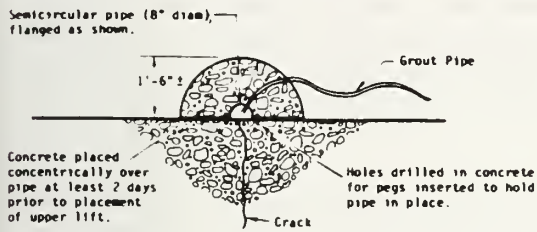

### 3.8—Crack arrest method of crack repair

ing on the width of the crack. However, the water-cement ratio should be kept as low as practical to maximize strength and minimize shrinkage. Water reducers or other admixtures may be used to improve the properties of the grout. For small volumes, a manual application gun may be used; for larger volumes, a pump may be used. After the crack is filled, the pressure should be maintained for several minutes to insure penetration.

**3.9 Chemical grouting** — Chemical grouts consist of combinations of two or more chemicals that combine to form a gel, a solid precipitate, or a foam, as opposed to cement grouts that consist of suspensions of solid particles in a fluid. Cracks in concrete as narrow as 0.01 in. (0.05 mm) have been filled with chemical grouts.

Advantages of chemical grouts include their application in moist environments (excess moisture acceptable), wide limits of control of gel time, and their effectiveness in very fine fractures. Disadvantages are the degree of skill needed for satisfactory use, their low strength, and the requirement that the grout not dry out in service.

### 3.10 Drypacking

Drypacking is the hand placement of a low water-cement mortar followed by tamping or ramming of the mortar into place, producing intimate contact between the mortar and the existing concrete.<sup>8</sup> Because of the low water-cement ratio of the material, there is little shrinkage, and the patch remains tight and is of good quality with respect to durability, strength, and water-tightness.

Drypack can be used for filling narrow slots cut for the repair of dormant cracks. The use of drypack is not suitable for filling or repairing active cracks. Before a crack may be repaired by drypacking, the concrete adjacent to the surface should be widened to a slot about 1 in. (25 mm) wide and 1 in. (25 mm) deep. This is most conveniently done with a power-driven chisel and bit. The slot should be undercut so that the width is slightly greater than the surface width.

After the slot is thoroughly cleaned and dried, a surface coat, consisting of cement slurry or equal quantities of cement and fine sand mixed with water to a paste consistency, should be applied. Placing of drypack mortar should begin immediately. The mortar consists of one part cement, three parts of sand passing a No. 16 (1.18 mm) sieve, and just enough wa-

ter so that the mortar will stick together when molded into a ball by hand.

If the patch must match the color of the surrounding concrete, a blend of portland cement and white cement may be used. Normally, about one-third white cement is adequate, but the precise proportions can only be determined by trial.

To minimize shrinkage in place, the mortar should stand for ½ hour after mixing and then be remixed prior to use. It should be placed in layers about ⅜ in. (10 mm) thick. Each layer should be thoroughly compacted over the entire surface using a blunt stick or hammer, and each layer should be scratched to facilitate bonding with the next layer. There need be no time delays between layers.

The mortar may be finished by laying the flat side of a hardwood piece against it and striking it several times with a hammer. Surface appearance may be improved by a few light strokes with a rag or sponge float. The repair should be cured by using either water or a curing compound. The simplest method of moist curing is to support a strip of folded wet burlap along the length of the crack.

### 3.10 — Crack arrest

During construction of massive concrete structures, cracks due to surface cooling or other causes may develop and propagate into new concrete as construction progresses. Such cracks may be arrested by blocking the crack and spreading the tensile stress over a larger area.<sup>57</sup>

A piece of bond-breaking membrane or a grid of steel mat may be placed over the crack as concreting continues. A semicircular pipe placed over the crack may also be used (Fig. 3.8). A description of installation procedures for semicircular pipes used during the construction of a massive concrete structure follows: (1) The semicircular pipe is made by splitting an 8 in. (200 mm), 16-gage pipe and bending it to a semicircular section with about a 3-in. (75-mm) flange on each side; (2) the area in the vicinity of the crack is cleaned; (3) the pipe is placed in sections so as to remain centered on the crack; (4) the sections are then welded together; (5) holes are cut in the top of the pipe to receive grout pipes; and (6) after setting the grout pipes, the installation is covered with concrete placed concentrically over the pipe by hand. The installed grout pipes are used for grouting the crack at a later date, thereby restoring all or a portion of the structural continuity.

### 3.11 — Polymer impregnation

Monomer systems can be used for effective repair of cracks. A monomer system is a liquid that consists of small organic molecules capable of combining to form a solid plastic. Monomers have varying degrees of volatility, toxicity, and flammability and do not mix with water. They are very fluid and will soak into dry concrete, filling the cracks, much the same as water does.

Monomer systems used for impregnation contain a catalyst or initiator and the basic monomer (or combi-



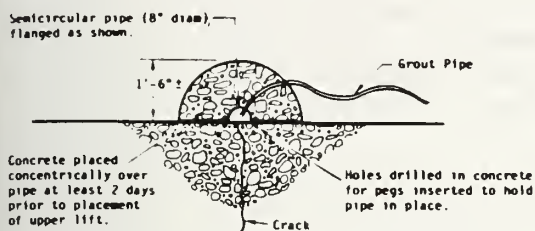

Fig. 3.8—Crack arrest method of crack repair

ing on the width of the crack. However, the water-cement ratio should be kept as low as practical to maximize strength and minimize shrinkage. Water reducers or other admixtures may be used to improve the properties of the grout. For small volumes, a manual injection gun may be used; for larger volumes, a pump should be used. After the crack is filled, the pressure should be maintained for several minutes to insure penetration.

**3.2 Chemical grouting** — Chemical grouts consist of solutions of two or more chemicals that combine to form a gel, a solid precipitate, or a foam, as opposed to cement grouts that consist of suspensions of solid particles in a fluid. Cracks in concrete as narrow as 0.02 in. (0.05 mm) have been filled with chemical grouts.

The advantages of chemical grouts include their applicability in moist environments (excess moisture available), wide limits of control of gel time, and their effectiveness in very fine fractures. Disadvantages are the degree of skill needed for satisfactory use, their low strength, and the requirement that the grout should not dry out in service.

### — Drypacking

Drypacking is the hand placement of a low water-cement mortar followed by tamping or ramming of the mortar into place, producing intimate contact between the mortar and the existing concrete.<sup>8</sup> Because of the low water-cement ratio of the material, there is little shrinkage, and the patch remains tight and is of good quality with respect to durability, strength, and water-tightness.

Drypack can be used for filling narrow slots cut for the repair of dormant cracks. The use of drypack is not suitable for filling or repairing active cracks.

Before a crack may be repaired by drypacking, the surface on adjacent to the surface should be widened to a width of about 1 in. (25 mm) wide and 1 in. (25 mm) deep. This is most conveniently done with a power-driven chisel and bit. The slot should be undercut so that the width is slightly greater than the surface width.

After the slot is thoroughly cleaned and dried, a surface coat, consisting of cement slurry or equal quantities of cement and fine sand mixed with water to a paste consistency, should be applied. Placing of the dry pack mortar should begin immediately. The mortar consists of one part cement, three parts of sand passing a No. 16 (1.18 mm) sieve, and just enough wa-

ter so that the mortar will stick together when molded into a ball by hand.

If the patch must match the color of the surrounding concrete, a blend of portland cement and white cement may be used. Normally, about one-third white cement is adequate, but the precise proportions can only be determined by trial.

To minimize shrinkage in place, the mortar should stand for ½ hour after mixing and then be remixed prior to use. It should be placed in layers about ¾ in. (10 mm) thick. Each layer should be thoroughly compacted over the entire surface using a blunt stick or hammer, and each layer should be scratched to facilitate bonding with the next layer. There need be no time delays between layers.

The mortar may be finished by laying the flat side of a hardwood piece against it and striking it several times with a hammer. Surface appearance may be improved by a few light strokes with a rag or sponge float. The repair should be cured by using either water or a curing compound. The simplest method of moist curing is to support a strip of folded wet burlap along the length of the crack.

### 3.10 — Crack arrest

During construction of massive concrete structures, cracks due to surface cooling or other causes may develop and propagate into new concrete as construction progresses. Such cracks may be arrested by blocking the crack and spreading the tensile stress over a larger area.<sup>57</sup>

A piece of bond-breaking membrane or a grid of steel mat may be placed over the crack as concreting continues. A semicircular pipe placed over the crack may also be used (Fig. 3.8). A description of installation procedures for semicircular pipes used during the construction of a massive concrete structure follows: (1) The semicircular pipe is made by splitting an 8 in. (200 mm), 16-gage pipe and bending it to a semicircular section with about a 3-in. (75-mm) flange on each side; (2) the area in the vicinity of the crack is cleaned; (3) the pipe is placed in sections so as to remain centered on the crack; (4) the sections are then welded together; (5) holes are cut in the top of the pipe to receive grout pipes; and (6) after setting the grout pipes, the installation is covered with concrete placed concentrically over the pipe by hand. The installed grout pipes are used for grouting the crack at a later date, thereby restoring all or a portion of the structural continuity.

### 3.11 — Polymer impregnation

Monomer systems can be used for effective repair of cracks. A monomer system is a liquid that consists of small organic molecules capable of combining to form a solid plastic. Monomers have varying degrees of volatility, toxicity, and flammability and do not mix with water. They are very fluid and will soak into dry concrete, filling the cracks, much the same as water does.

Monomer systems used for impregnation contain a catalyst or initiator and the basic monomer (or combi-



nation of monomers). They may also contain a cross-linking agent. When heated, the monomers join together, or polymerize, becoming a tough, strong, durable plastic that greatly enhances a number of concrete properties.

If a cracked concrete surface is dried, flooded with the monomer, and polymerized in place, the cracks will be filled and structurally repaired. However, if the cracks contain moisture, the monomer will not soak into the concrete at each crack face, and consequently, the repair will be unsatisfactory. If a volatile monomer evaporates before polymerization, it will be ineffective. Polymer impregnation has not been used successfully to repair fine cracks.

Badly fractured beams have been repaired using polymer impregnation by drying the fracture, temporarily encasing it in a watertight (monomer proof) band of sheet metal, soaking the fractures with monomer, and polymerizing the monomer. Large voids or broken areas in compression zones can be filled with fine and coarse aggregate before flooding them with the monomer, providing a polymer-concrete repair. A more detailed discussion of polymers is given in ACI 548R.

### 3.12 — Overlays and surface treatments

Cracks in both structural and pavement slabs may be repaired using bonded overlays if the slabs are not subject to movement (note, unbonded overlays can be used to cover but not necessarily repair slabs). However, most cracks in slabs are subject to movement caused by variations in loading, temperature, and moisture. These cracks will reflect through any bonded overlay, negating the overlay insofar as crack repair is concerned (ACI 224R). However, slabs with numerous fine cracks caused by drying shrinkage or other one-time occurrences can be effectively repaired by the use of overlays.

Slabs-on-grade in freezing climates should never receive an overlay or surface treatment that is a vapor barrier. An impervious barrier will cause moisture passing from the subgrade to condense under the barrier, leading to critical saturation of the concrete and rapid disintegration by cycles of freezing and thawing.

Low solid, epoxy resin-based systems have been used to seal the surface of concrete (including very fine cracks). They are most suitable for use on surfaces that are not subject to wear. Typically, 17 to 25 percent solvent solutions of epoxy resin systems conforming to ASTM C 881 viscosity Grade I, Type I, II, or III are used. The effectiveness of these materials has not been fully established.

Bridge and parking decks and interior slabs may be effectively coated using a heavy coat [60 mils  $\pm$  mils (1.5 mm  $\pm$  0.25 mm)] of epoxy resin. The treatment should include broadcasting of aggregate on the uncured resin. This method is covered in ACI 503.3. ASTM C 881 Type III, viscosity Grade I or II covers suitable epoxy resin systems. The method will close dormant cracks, even if the skid-resistant aggregate is abraded from the surface, since traffic can not abrade the resin that has penetrated the cracks.

Slabs and decks containing fine dormant cracks can be repaired by applying an overlay of polymer-modified portland cement concrete or mortar. In highway bridge applications a minimum overlay thickness of 1 1/2 in. (38 mm) has been used successfully.<sup>20</sup> Polymers suitable for such applications are latexes of styrene butadiene, acrylic, non-reemulsifiable polyvinyl acetate, and certain water-compatible epoxy resin systems. The minimum resin solids should be 15 percent by weight of the portland cement, with 20 percent by weight of the cement usually being optimum.<sup>57</sup>

Prior to overlay application, the surface should be cleaned to remove laitance, carbonation, or contaminants, such as grease or oil. A bond coat consisting of broomed latex mortar or an epoxy adhesive should be applied immediately before placing the overlay. Since latex normally solidifies rapidly, continuous batching and mixing equipment should be employed. The polymer-modified overlay should be mixed, placed, and finished rapidly (within 15 minutes in warm weather). Disturbing the overlay after the latex begins to solidify will result in cracking of the overlay. Such overlays should be cured for 24 hours.

### 3.13 — Autogenous healing

A natural process of crack repair known as "autogenous healing" can occur in concrete in the presence of moisture and absence of tensile stress.<sup>58</sup> It has practical application for closing dormant cracks in a moist environment, such as may be found in mass concrete structures.

Healing occurs through the carbonation of calcium hydroxide in the cement paste by carbon dioxide, which is present in the surrounding air and water. Calcium carbonate and calcium hydroxide crystals precipitate, accumulate, and grow within the cracks. The crystals interlace and twine, producing a mechanical bonding effect, which is supplemented by a chemical bonding between adjacent crystals and between the crystals and the surfaces of the paste and the aggregate. As a result, some of the tensile strength of the concrete is restored across the cracked section, and the crack may become sealed.

Healing will not occur if the crack is active and is subjected to movement during the healing period. Healing will also not occur if there is a positive flow of water through the crack, which dissolves and washes away the lime deposit, unless the flow of water is so slow that complete evaporation occurs at the exposed face causing redeposition of the dissolved salts.

Saturation of the crack and the adjacent concrete with water during the healing process is essential for developing any substantial strength. Submergence of the cracked section is desirable. Alternatively, water may be ponded on the concrete surface so that the crack is saturated. The saturation must be continuous for the entire period of healing. A single cycle of drying and reimmersion will produce a drastic reduction in the amount of healing strength. Healing should be commenced as soon as possible after the crack appears.



ed healing results in less restoration of strength does immediate correction.

#### CHAPTER 4 — SUMMARY

s report is intended to serve as a tool in the pro- of crack evaluation and repair of concrete struc-

e causes of cracks in concrete are summarized with the principal procedures used for crack con- Both plastic and hardened concrete are consid- The importance of design, detailing, construction edures, concrete proportioning, and material rties are discussed.

e techniques and methodology for crack evalua- are described. Both analytical and field require- s are discussed. The need to determine the cause or s of cracking as a necessary prerequisite to repair phasized. The selection of successful repair tech- s should consider (1) the causes of cracking, (2) her the cracks are active or dormant, and (3) the for repairs. Criteria for the selection of crack re- procedures are based on the desired outcome of the rs.

elve methods of crack repair are presented, in- ng the techniques, advantages and disadvantages, reas of application of each.

#### CHAPTER 5 — REFERENCES

##### - Recommended references

e documents of the various standards-producing izations referred to in this report are listed below their serial designation, including year of adop- or revision. The documents listed were the latest at the time this report was written. Since some of documents are revised frequently, generally in detail only, the user of this report should check ly with the sponsoring group if it is desired to re- the latest revision.

*American Association of State Highway and Transpor- Officials*  
Standard Specification for Highway Bridges, 12th Edi- (1977)

##### *American Concrete Institute*

R (Reaffirmed 1979) Guide for Mak- ing a Condition Survey of Concrete in Service  
R (Reaffirmed 1982) Guide to Dura- ble Concrete  
R (Reaffirmed 1980) Mass Concrete for Dams and Other Massive Struc- tures  
R (Reaffirmed 1980) Effect of Re- straint, Volume Change, and Rein- forcement on Cracking of Massive Concrete  
Control of Cracking in Concrete Structures

302.1R	Guide to Concrete Floor and Slab Construction
304-73	(Reaffirmed 1983) Recommended Practice for Measuring, Mixing Transporting and Placing Concrete (Revised 1982) Hot Weather Con- creting
305R	Standard Practice for Curing Con- crete
308-81	(Revised 1982) Standard Practice for Consolidation of Concrete
309-72	Identification and Control of Con- solidation-Related Surface Defects in Formed Concrete
309.2R	Building Code Requirements for Reinforced Concrete
318-83	Standard Practice for Concrete Highway Bridge Deck Construction (Reaffirmed 1984) Recommended Practice for Concrete Formwork
345-82	Concrete Sanitary Engineering Structures
347-78	Use of Epoxy Compounds with Concrete
350R	Standard Specification for Produc- ing a Skid-Resistant Surface on Concrete by the Use of a Multi- Component Epoxy System
503R	Guide to Joint Sealants for Con- crete Structures
503.3-79	Accelerated Curing of Concrete at Atmospheric Pressure-State of the Art
504R	Guide for Repair of Concrete Bridge Superstructures (Reaffirmed 1981) Polymers in Concrete
517.2R	<i>American Society for Testing and Materials</i>
546.1R	C 595-82 Standard Specification for Blended Hydraulic Cements
548R	C 597-71 (Reapproved 1979) Standard Test Method for Pulse Velocity through Concrete
	C 876-80 Standard Test Method for Half Cell Potentials of Reinforcing Steel in Concrete
	C 881-78 Standard Specification for Epoxy- Resin-Base Bonding Systems for Concrete

The above publications may be obtained from the fol- lowing organizations:

American Association of State Highway and Transportation Officials  
333 N Capitol St NW  
Suite 225  
Washington, D.C. 20001





American Concrete Institute  
P.O. Box 19150  
Detroit, MI 48219

American Society for Testing and Materials  
1916 Race St  
Philadelphia, PA 19103

## 5.2 — Cited references

1. Kelly, Joe W., "Cracks in Concrete: Part 1, Part 2," *Concrete Construction*, V. 26, No. 9, Sept. 1981, pp. 725-734.
2. Price, Walter H., "Control of Cracking of Concrete During Construction," *Concrete International: Design & Construction*, V. 4, No. 1, Jan. 1982, pp. 40-43.
3. Carlson, Roy W.; Houghton, Donald L.; and Polivka, Milos, "Causes and Control of Cracking in Unreinforced Mass Concrete," *ACI JOURNAL, Proceedings* V. 76, No. 7, July 1979, pp. 821-837.
4. Abdun-Nur, Edward A., "Cracking of Concrete—Who Cares?," *Concrete International: Design & Construction*, V. 5, No. 7, July 1983, pp. 27-30.
5. Dakhil, Fadh H.; Cady, Philip D.; and Carrier, Roger E., "Cracking of Fresh Concrete as Related to Reinforcement," *ACI JOURNAL, Proceedings* V. 72, No. 8, Aug. 1975, pp. 421-428.
6. Pickett, Gerald, "Effect of Aggregate on Shrinkage of Concrete and Hypothesis Concerning Shrinkage," *ACI JOURNAL, Proceedings* V. 52, No. 5, Jan. 1956, pp. 581-590.
7. Carlson, Roy W., "Drying Shrinkage of Concrete as Affected by Many Factors," *Proceedings ASTM*, V. 38, Part 2, 1938, pp. 419-437.
8. *Concrete Manual*, 8th Edition, U. S. Bureau of Reclamation, Denver, 1975, 627 pp.
9. Dusinberre, D. M., "Numerical Methods for Transient Heat Flow," *Transactions*, American Society of Mechanical Engineers, V. 67, Nov. 1945, pp. 703-712.
10. Houghton, Donald L., "Determining Tensile Strain Capacity of Mass Concrete," *ACI JOURNAL, Proceedings* V. 73, No. 12, Dec. 1976, pp. 691-700.
11. Houghton, Donald L., "Concrete Strain Capacity Tests—Their Economic Implications," *Economical Construction of Concrete Dams*, American Society of Civil Engineers, New York, 1972, pp. 75-99.
12. Priestly, M. J., Nigel, "Design of Concrete Bridges for Temperature Gradients," *ACI JOURNAL, Proceedings* V. 75, No. 5, May 1978, pp. 209-217.
13. Hoffman, P. C.; McClure, R. M.; and West, H. H., "Temperature Study of an Experimental Segmental Concrete Bridge," *Journal*, Prestressed Concrete Institute, V. 28, No. 2, Mar.-Apr. 1983, pp. 78-97.
14. Powers, T. C., "Freezing Effects in Concrete," *Durability of Concrete*, SP-47, American Concrete Institute, Detroit, 1975, pp. 1-11.
15. Snowdon, L. C., and Edwards, A. G., "The Moisture Movement of Natural Aggregate and its Effect on Concrete," *Magazine of Concrete Research* (London), V. 14, No. 41, July 1962, pp. 109-116.
16. Callan, Edwin J., "Thermal Expansion of Aggregates and Concrete Durability," *ACI JOURNAL, Proceedings* V. 48, No. 6, Feb. 1952, pp. 485-504.
17. Verbeck, George J., "Mechanisms of Corrosion of Steel in Concrete," *Corrosion of Metals in Concrete*, SP-49, American Concrete Institute, Detroit, 1975, pp. 21-38.
18. Beeby, A. W., "Cracking, Cover, and Corrosion of Reinforcement," *Concrete International: Design & Construction*, V. 5, No. 2, Feb. 1983, pp. 35-40.
19. Gergely, Peter, "Role of Cover and Bar Spacing in Reinforced Concrete," *Significant Developments in Engineering Practice and Research*, SP-72, American Concrete Institute, Detroit, 1981, pp. 133-147.
20. "Durability of Concrete Bridge Decks," *NCHRP Synthesis of Highway Practice* No. 57, Transportation Research Board, Washington, D. C., May 1979, 61 pp.
21. Verbeck, George, "Carbonation of Hydrated Portland Cement," *Cement and Concrete*, STP-205, American Society for Testing and Materials, Philadelphia, 1958, pp. 17-36. Also, *Research Department Bulletin* No. 87, Portland Cement Association.
22. Shideler, Joseph J., and Toennies, Henry T., "Plant Drying and Carbonation of Concrete Block—NCMA-PCA Cooperative Program," *ACI JOURNAL, Proceedings* V. 60, No. 5, May 1963, pp. 617-634. Also, *Development Department Bulletin* No. D64, Portland Cement Association.
23. Kirkbride, T. W., "Burner Curing," *Precast Concrete* (London), V. 2, No. 11, Nov. 1971, pp. 644-646.
24. Higginson, Elmo C., "Effect of Stream Curing on the Important Properties of Concrete," *ACI JOURNAL, Proceedings* V. 58, No. 3, Sept. 1961, pp. 281-298.
25. Jastrzebski, Zbigniew D., *Nature and Properties of Engineering Materials*, John Wiley and Sons, New York, 1961, 571 pp.
26. Kirkbride, T., "Review of Accelerated Curing Procedures," *Precast Concrete* (London), V. 2, No. 2, Feb. 1971, pp. 87-90.
27. Mansfield, G. A., "Curing—A Problem in Thermodynamics," *Rock Products*, V. 51, No. 8, Aug. 1948, p. 212.
28. Nurse, R. W., "Steam Curing of Concrete," *Magazine of Concrete Research* (London), V. 1, No. 2, June 1949, pp. 79-88.
29. PCI Energy Committee, Discussion of "Accelerated Curing of Concrete at Atmospheric Pressure—State of the Art," *ACI JOURNAL, Proceedings*, July-August 1981, pp. 320-324.
30. Butt, Yu. M.; Kolbasov, V. M.; and Timashev, V. V., "High Temperature Curing of Concrete Under Atmospheric Pressure," *Proceedings*, 5th International Symposium on the Chemistry of Cement (Tokyo, 1968), Cement Association of Japan, 1969, pp. 437-476.
31. *Third Progress Report of the Low Pressure Steam-Curing Concrete*, Concrete Institute of Australia, North Sydney, 1972, 26 pp.
32. Kaminetzky, Dov, "Failures During and After Construction," *Concrete Construction*, V. 26, No. 8, Aug. 1981, pp. 641-649.
33. Libby, James R., *Modern Prestressed Concrete*, 2nd Edition, Van Nostrand Reinhold, New York, 1977, pp. 388-390.
34. Mast, Robert F., "Roof Collapse at Antioch High School," *Journal*, Prestressed Concrete Institute, V. 26, No. 3, May-June 1981, pp. 29-53.
35. Gergely, Peter, and Lutz, Leroy A., "Maximum Crack Width in Reinforced Concrete Flexural Members," *Causes, Mechanism, and Control of Cracking in Concrete*, SP-20, American Concrete Institute, Detroit, 1968, pp. 87-117.
36. Broms, Bengt B., "Crack Width and Crack Spacing in Reinforced Concrete Members," *ACI JOURNAL, Proceedings* V. 62, No. 10, Oct. 1965, pp. 1237-1256.
37. Broms, Bengt B., and Lutz, Leroy A., "Effects of Arrangement of Reinforcement on Crack Width and Spacing of Reinforced Concrete Members," *ACI JOURNAL, Proceedings* V. 62, No. 11, Nov. 1965, pp. 1395-1410.
38. Illston, J. M., and Stevens, R. F., "Long-Term Cracking in Reinforced Concrete Beams," *Proceedings Institution of Civil Engineers* (London), Part 2, V. 53, Dec. 1972, pp. 445-459.
39. Holmberg, Ake, "Crack Width Prediction and Minimum Reinforcement for Crack Control," *Dansk Selskab for Byggesstatik* (Copenhagen), V. 44, No. 2, June 1973, pp. 41-50.
40. Abeles, Paul W.; Brown, Earl L. II; and Morrow, Joe W., "Development and Distribution of Cracks in Rectangular Prestressed Beams During Static and Fatigue Loading," *Journal*, Prestressed Concrete Institute, V. 13, No. 5, Oct. 1968, pp. 36-51.
41. Bennett, E. W., and Dave, N. J., "Test Performances and Design of Concrete Beams with Limited Prestress," *The Structural Engineer* (London), V. 47, No. 12, Dec. 1969, pp. 487-496.
42. Rehm, Gallus, and Eligenhausen, Rolf, "Lapped Splices of Deformed Bars Under Repeated Loadings (Ubergreifungsstosse von Rippenstahlen unter nicht ruhender Belastung)," *Beton und Stahlbetonbau* (Berlin), No. 7, 1977, pp. 170-174.
43. Stratton, F. Wayne; Alexander, Roger; and Nolting, William, "Cracked Structural Concrete Repair through Epoxy Injection and Rebar Insertion," *Report* No. FHWA-KS-RD-78-3, Kansas Department of Transportation, Topeka, Nov. 1978, 56 pp.
44. "Forensic Investigations—Part I. Some Tools," *Building Failure Forum*, V. 1, No. 6, June 1981, pp. 11-12.



ar, K. C., and Hay, R. L., "Time-to-Corrosion of Rein-  
steel in Concrete Slabs. V. 1, Effects of Mix Design and  
ion Parameters," Report No. FHWA-RD-73-32, Federal  
Administration, Washington, D. C., 1973, 103 pp.  
hotra, V. M., *Testing Hardened Concrete: Nondestructive*  
ACI Monograph No. 9, American Concrete Institute, Iowa  
versity Press, Detroit, 1976, 188 pp.  
ab, I. I.; Blessing, G. V.; and Clifton, J. R., "Laboratory  
on of Ultrasonics for Crack Detection in Concrete," ACI  
*Proceedings* V. 80, No. 1, Jan.-Feb. 1983, pp. 17-27.  
exander, A. Michel, "Development of Procedures for Non-  
e Testing of Concrete Structures: Report 2, Feasibility of  
se-Echo Technique," *Miscellaneous Paper No. C-77-11*,  
my Engineer Waterways Experiment Station, Vicksburg,  
pp.  
oncrete Repair and Restoration," *ACI Compilation No. 5*,  
n Concrete Institute, Detroit, 1980, 118 pp. (compiled from  
*International Design & Construction*, V. 2, No. 9, Sept.

52. Stratton, I. Wayne, "Custom Concrete Drill Helps Repair  
Shear Cracks in Bridge Girders," *Concrete International: Design &  
Construction*, V. 2, No. 9, Sept. 1980, pp. 118-119.  
53. Stratton, I. Wayne; Alexander, Roger; and Nolting, William,  
"Development and Implementation of Concrete Girder Repair by  
Post-Reinforcement," Report No. FHWA-KS-82-1, Kansas Depart-  
ment of Transportation, Topeka, May 1982, 31 pp.  
54. Nilson, Arthur H., *Design of Prestressed Concrete*, John Wiley  
& Sons, New York, 1978, 526 pp.  
55. Lin, T. Y., and Burns, Ned H., *Design of Prestressed Con-  
crete Structures*, 3rd Edition, John Wiley & Sons, New York, 1981,  
646 pp.  
56. "Concrete Operation with Relation to Cracking at Norfolk  
Dam," *Final Report*, U. S. Army Corps of Engineers, Little Rock  
District, Arkansas, Oct. 1945.  
57. Clear, Kenneth C., and Chollar, Brian H., "Styrene-Butadiene  
Latex Modifiers for Bridge Deck Overlay Concrete," Report No.  
FHWA-RD-78-35, Federal Highway Administration, Washington,  
D. C., Apr. 1978, 124 pp.  
58. Lauer, Kenneth R., and Slate, Floyd O., "Autogenous Heal-  
ing of Cement Paste," *ACI JOURNAL, Proceedings* V. 27, No. 10,  
June 1956, pp. 1083-1098.

This report was submitted to letter ballot of the committee which consists of  
16 members: 16 were affirmative. It has been processed in accordance with In-  
stitute procedure and is approved for publication and discussion.

**ACI COMMITTEE 224  
Cracking**

David Darwin\*  
Chairman  
Roy W. Carlson  
William L. Clark, Jr.  
Peter Gergely  
Donald L. Houghton  
Paul H. Karr †  
Lawrence I. Knab

Grant T. Halvorsen  
Secretary  
Tony C. Liu\*  
LeRoy Lutz  
David G. Manning  
E. G. Nawy  
Robert E. Philleo †  
Milos Polivka

Andrew Scanlon\*  
Lewis H. Tuthill  
Ted E. Webster  
Orville R. Werner  
Zenon A. Zieliński

**Corresponding members**

Alfred G. Bishara †

J. P. Lloyd

Robert L. Yuan †

**Consulting members**

Julius G. Potyondy

Ernest K. Schrader

Raymond J. Schutz †\*\*

\* principal author.  
† consulting author.  
‡ committee member.  
§ member consultant.



## REFERENCE LIST

1. A Professional's Handbook on Grouting, Concrete Repair, and Waterproofing, Five Star Products, Inc., 1991.
2. Papadakis, Vagelis G., C.G. Vayenas, and M.N. Fardis, "Physical and Chemical Characteristics Affecting the Durability of Concrete", ACI Materials Journal, American Concrete Institute, Detroit, Vol. 8, No. 2, March-April 1991, p. 186.
3. Ropke, John C., Concrete Problems: Causes and Cures, McGraw-Hill, Inc., New York, 1982, 187 pp.
4. ACI Committee 201, "Guide for Making a Condition Survey of Concrete in Service", (ACI 201.1R-68, Revised 1984), American Concrete Institute, Detroit, 1984, 14 pp.
5. American Concrete Institute, Troubleshooting Concrete Construction, Course Manual SCM-22, American Concrete Institute, Detroit, 1990, 348 pp.
6. ACI Committee 224, "Causes, Evaluation, and Repair of Cracks in Concrete", (ACI 224.1R-89), American Concrete Institute, Detroit, 1989. 20 pp.
7. ACI Committee 302, "Guide for Concrete Floor and Slab Construction", (ACI 301.1R-89), American Concrete Institute, Detroit, 1989, 45 pp.
8. Waddell, Joseph J., Concrete Manual, International Conference of Building Officials, Whittier, 1989, 352 pp.
9. ACI Committee 201, "Guide for Making a Condition Survey of Concrete Pavements", (ACI 210.3R-86), American Concrete Institute, Detroit, 1986, 22 pp.
10. Perkins, Philip H., Repair, Protection and Waterproofing of Concrete Structures, Elsevier Applied Science Publishers, London, 1986, 302 pp.
11. American Concrete Institute, Repair and Rehabilitation of Concrete Structures, ACI Compilation No. 10, American Concrete Institute, Detroit, 1989, 92 pp.



## REFERENCE LIST

1. A Professional's Handbook on Grouting, Concrete Repair, and Waterproofing, Five Star Products, Inc., 1991.
2. Papadakis, Vagelis G., C.G. Vayenas, and M.N. Fardis, "Physical and Chemical Characteristics Affecting the Durability of Concrete", ACI Materials Journal, American Concrete Institute, Detroit, Vol. 8, No. 2, March-April 1991, p. 186.
3. Ropke, John C., Concrete Problems: Causes and Cures, McGraw-Hill, Inc., New York, 1982, 187 pp.
4. ACI Committee 201, "Guide for Making a Condition Survey of Concrete in Service", (ACI 201.1R-68, Revised 1984), American Concrete Institute, Detroit, 1984, 14 pp.
5. American Concrete Institute, Troubleshooting Concrete Construction, Course Manual SCM-22, American Concrete Institute, Detroit, 1990, 348 pp.
6. ACI Committee 224, "Causes, Evaluation, and Repair of Cracks in Concrete", (ACI 224.1R-89), American Concrete Institute, Detroit, 1989. 20 pp.
7. ACI Committee 302, "Guide for Concrete Floor and Slab Construction", (ACI 301.1R-89), American Concrete Institute, Detroit, 1989, 45 pp.
8. Waddell, Joseph J., Concrete Manual, International Conference of Building Officials, Whittier, 1989, 352 pp.
9. ACI Committee 201, "Guide for Making a Condition Survey of Concrete Pavements", (ACI 210.3R-86), American Concrete Institute, Detroit, 1986, 22 pp.
10. Perkins, Philip H., Repair, Protection and Waterproofing of Concrete Structures, Elsevier Applied Science Publishers, London, 1986, 302 pp.
11. American Concrete Institute, Repair and Rehabilitation of Concrete Structures, ACI Compilation No. 10, American Concrete Institute, Detroit, 1989, 92 pp.





12. American Concrete Institute, Concrete Repair Basics, Course Manual SCM-24, American Concrete Institute, Detroit, 1991, 375 pp.
13. American Concrete Institute, Repairs of Concrete Structures--Assessments, methods and risks, Course Manual SCM-21, American Concrete Institute, Detroit, 1989, 514 pp.
14. American Society for Testing and Materials, "Standard Specification for Epoxy-Resin Base Bonding Systems for Concrete", (ASTM C 881-78, Reapproved 1983), American Society for Testing and Materials, Philadelphia, 1983, 4 pp.
15. American Concrete Institute, Structural Repair--Corrosion Damage and Control, Course Manual SCM-8, American Concrete Institute, Detroit, 1985, 233 pp.
16. Portland Cement Association, Basic Concrete Construction Practices, John Wiley & Sons, Inc., New York, 1980, 468 pp.
17. ACI Committee 201, "Guide to Durable Concrete", (ACI 201.2R-77), American Concrete Institute, Detroit, 1977, p.32
18. ACI Committee 224, "Control of Cracking in Concrete Structures", (ACI 224R-90), American Concrete Institute, Detroit, 1990, 43 pp.
19. Murray, Myles A., "Epoxy injection welds cracks back together", Concrete Construction, The Aberdeen Group, Vol. 32 No. 1, Addison, Jan 1987, 3 pp.
20. Metzgar, Steven N., "Repairing joints in industrial floors", Concrete Construction, The Aberdeen Group, Vol. 34 No. 6, Addison, June 1989, 4 pp.
21. Barfoot, Jack, "Tackle the cause--not the effect!", Concrete, London, Dec 1990, 2 pp.











Thesis  
S49345 Siegfried  
c.1 Evaluation and repair  
of concrete slabs.

Thesis  
S49345 Siegfried  
c.1 Evaluation and repair  
of concrete slabs.

DUDLEY KNOX LIBRARY



3 2768 00036913 6